

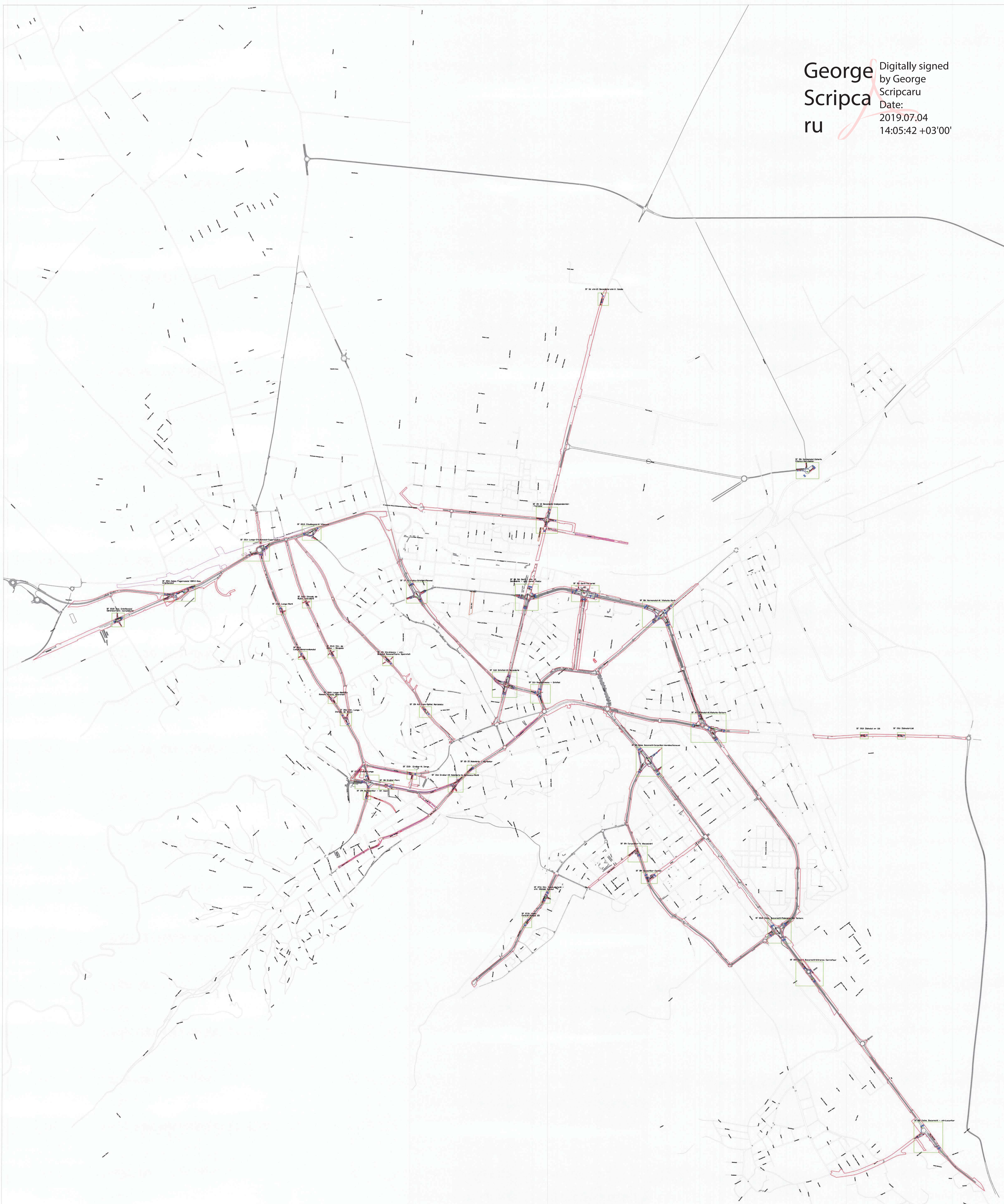

Proiectat	M. Gîgore	Verificat	V. Stan	Aprobat	V. Stan
Desenat	M. Gîgore	Data	octombrie 2018	Scara	
Denumire proiect:			Plan General		Faza
"Sistem centralizat de monitorizare și control al traficului în Municipiul Braşov"			Municipiul Braşov		SF
Proiectant:			Nr. desen:	246/71723-2208-SF-00	A0
SC.AM.PROIECT.DESIGN&CONSULTING SRL					

George
Scripcaru
ru

Digitally signed
by George
Scripcaru
Date:
2019.07.04
14:05:42 +03'00'



- LEGENDA
- semnalor vehicule
 - semnalor pietoni
 - VIDCSP
 - sublin semnalor pietoni
 - zona detectie video
 - cameră video fixă
 - cameră video mobilă
 - BRD
 - ADP
 - ADP
 - consoletă semnalor
 - cameră de înregistrare
 - aportor la linie optică
 - detector vehicul agent
 - Dispozitiv radio LoRa
 - zona studiată
 - linia mobilă
 - Planșă urbană



Proiectant: M. Grigore	Verificat: V. Stan	Aprobat: V. Stan	
Desenat: M. Grigore	Data: octombrie 2018	Scara:	
Denumire proiect: "Sistem centralizat de monitorizare și control al traficului în Municipiul Brașov"			Faza: SF
Proiectant: PLAN DE INCADRARE IN ZONA Municipiul Brașov			
SC AM PROJECT DESIGN & CONSULTING SRL	Nr. 666/17	246/1723-2208-SF-01	A0

SF-02: Calea Bucuresti - str.Lacurilor

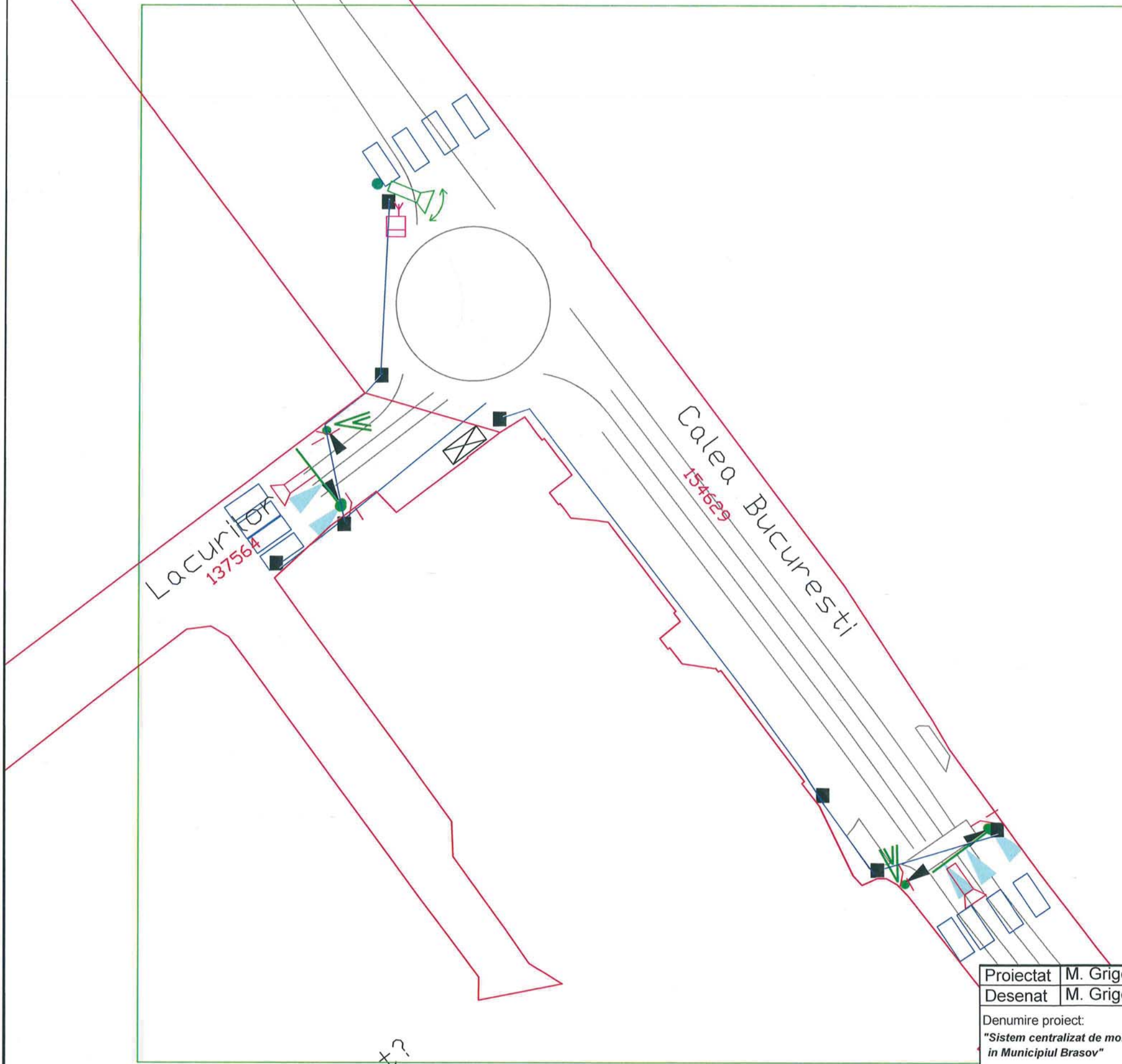

- LEGENDA:
- semafor vehicule
 - semafor pietoni
 - VID/GIP
 - buton semafor pietoni
 - zona detectie video
 - camera video fixa
 - camera video mobila
 - ADC
 - stalp
 - consola semafor
 - camereta de tragere
 - sapatura fibra optica
 - detector vehicul oprit
 - Dispozitiv radio LoRa
 - zona studiata
 - limita imobile
 - Panou afisare



Me?ot?

Proiectat	M. Grigore	Verificat	V. Stan	Aprobat	V. Stan
Desenat	M. Grigore	Data	octombrie 2018	Scara	
Denumire proiect: "Sistem centralizat de monitorizare si control al traficului in Municipiul Brasov"			PLAN DE SITUATIE Semaforizare intersectie Calea Bucuresti-str. Lacurilor		Faza: SF
Proiectant: SC AM PROJECT DESIGN & CONSULTING SRL			Nr. desen: 246/71723-2208-SF-02		A3

SF 03.1: Calea Bucuresti-intrarea Carrefour

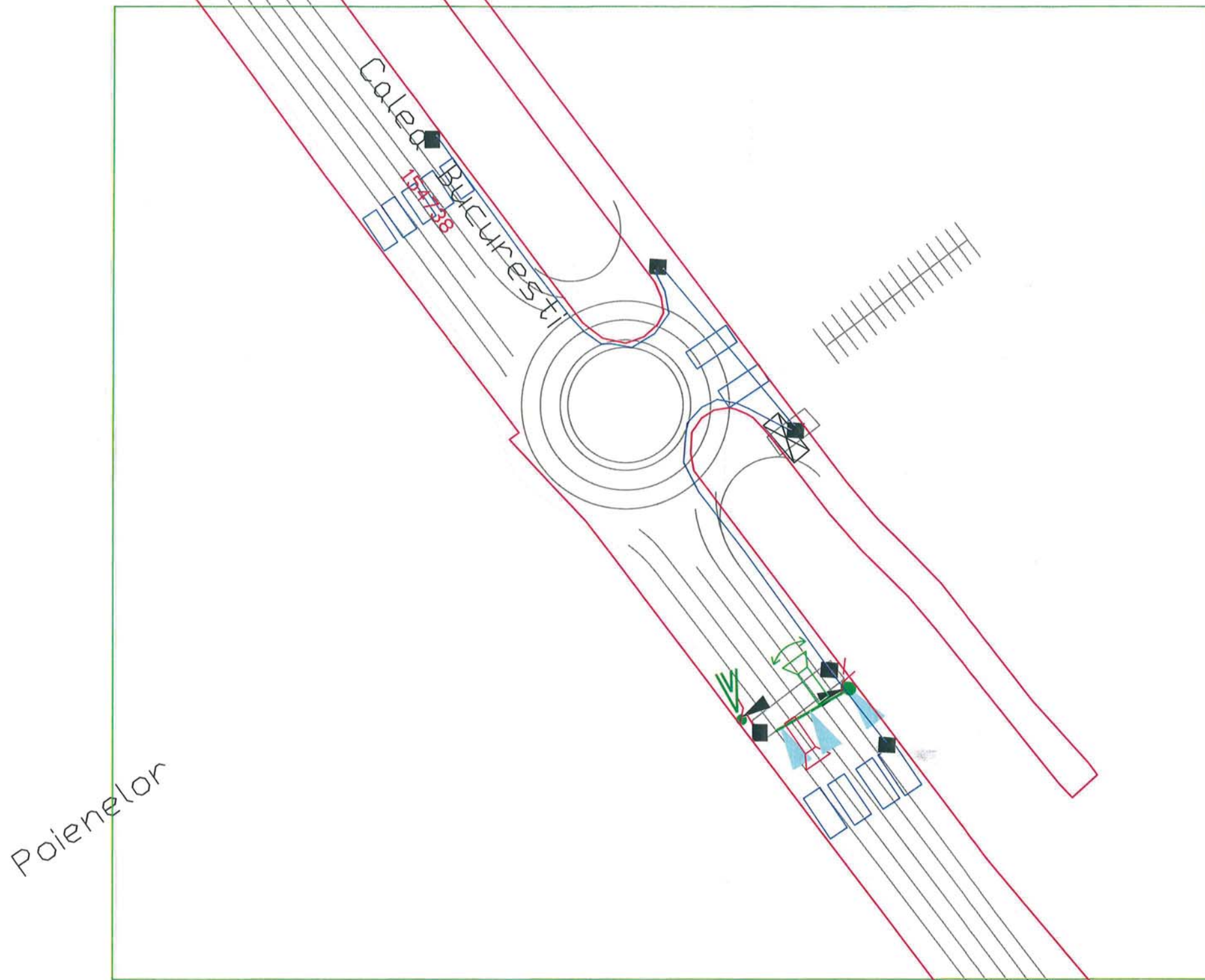

- LEGENDA:
- semafor vehicule
 - semafor pietoni
 - VID/GIP
 - buton semafor pietoni
 - zona detectie video
 - camera video fixa
 - camera video mobila
 - ADC
 - stalp
 - consola semafor
 - camereta de tragere
 - sapatura fibra optica
 - detector vehicul oprit
 - Dispozitiv radio LoRa
 - zona studiata
 - limita imobile
 - Panou afisare



Proiectat	M. Grigore	Verificat	V. Stan	Aprobat	V. Stan
Desenat	M. Grigore	Data	octombrie 2018	Scara	
Denumire proiect: "Sistem centralizat de monitorizare si control al traficului in Municipiul Brasov"			PLAN DE SITUATIE Semaforizare intersectie Calea Bucuresti-intrarea Carefour		Faza: SF
Proiectant: SC AM PROJECT DESIGN & CONSULTING SRL			Nr. desen:	246/71723-2208-SF-03.1	A3

SF 03.2: Calea Bucuresti-Poienelor-Bd. Saturn

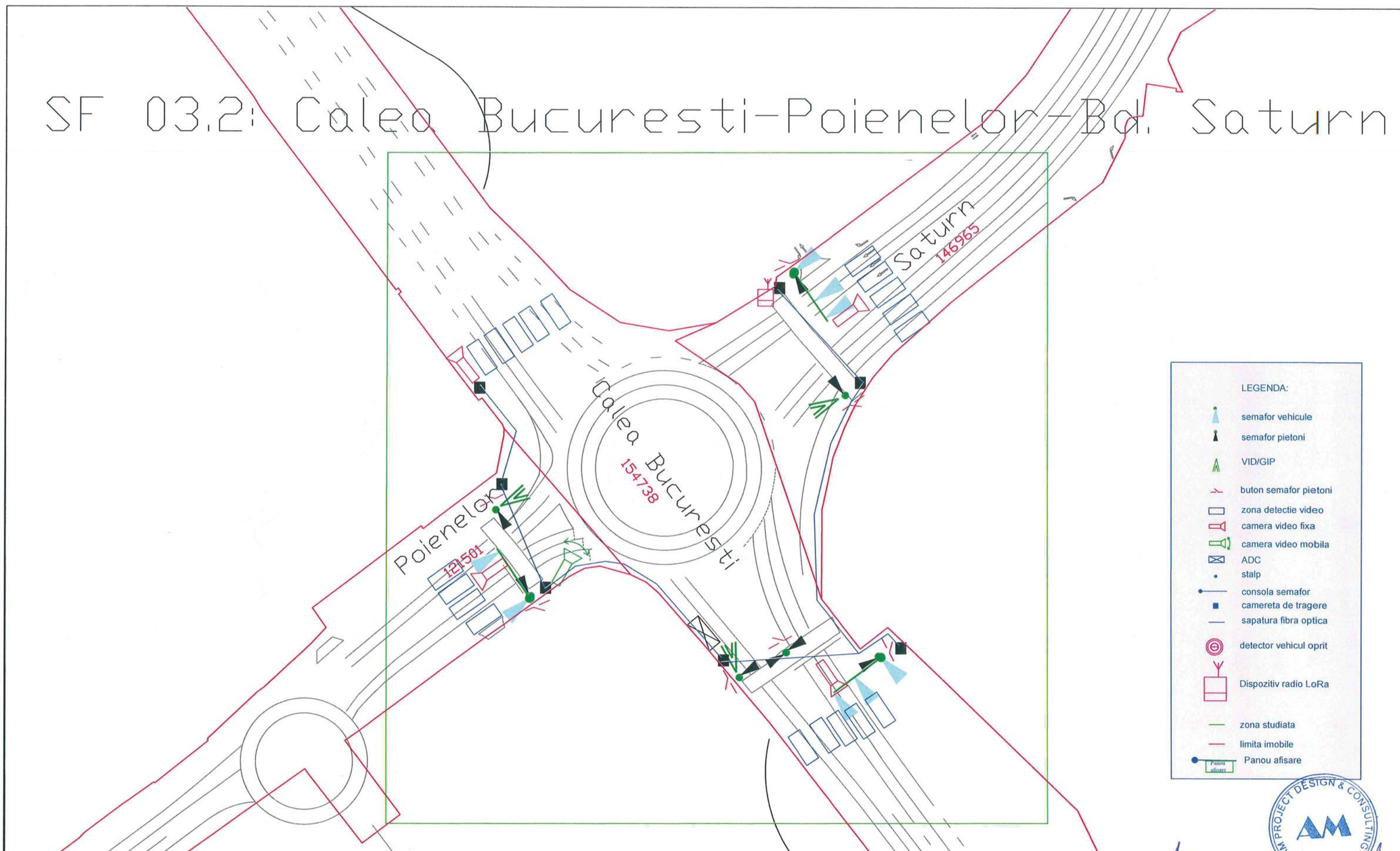

- LEGENDA:
- semafor vehicule
 - semafor pietoni
 - VID/GIP
 - buton semafor pietoni
 - zona detectie video
 - camera video fixa
 - camera video mobila
 - ADC
 - stalp
 - consola semafor
 - camereta de tragere
 - sapatura fibra optica
 - detector vehicul oprit
 - Dispozitiv radio LoRa
 - zona studiata
 - limita imobile
 - Panou afisare



Proiectat	M. Grigore	Verificat	V. Stan	Aprobat	V. Stan
Desenat	M. Grigore	Data	octombrie 2018	Scara	
Denumire proiect: "Sistem centralizat de monitorizare si control al traficului in Municipiul Brasov"			PLAN DE SITUATIE Semaforizare intersectie Calea Bucuresti-str. Poienelor-Bd. Saturn		Faza: SF
Proiectant: SC AM PROJECT DESIGN & CONSULTING SRL			Nr. desen: 246/71723-2208-SF-03.2		A3

SF 05: Calea Bucuresti-Carpatilor-Aurelian;Tarnavei

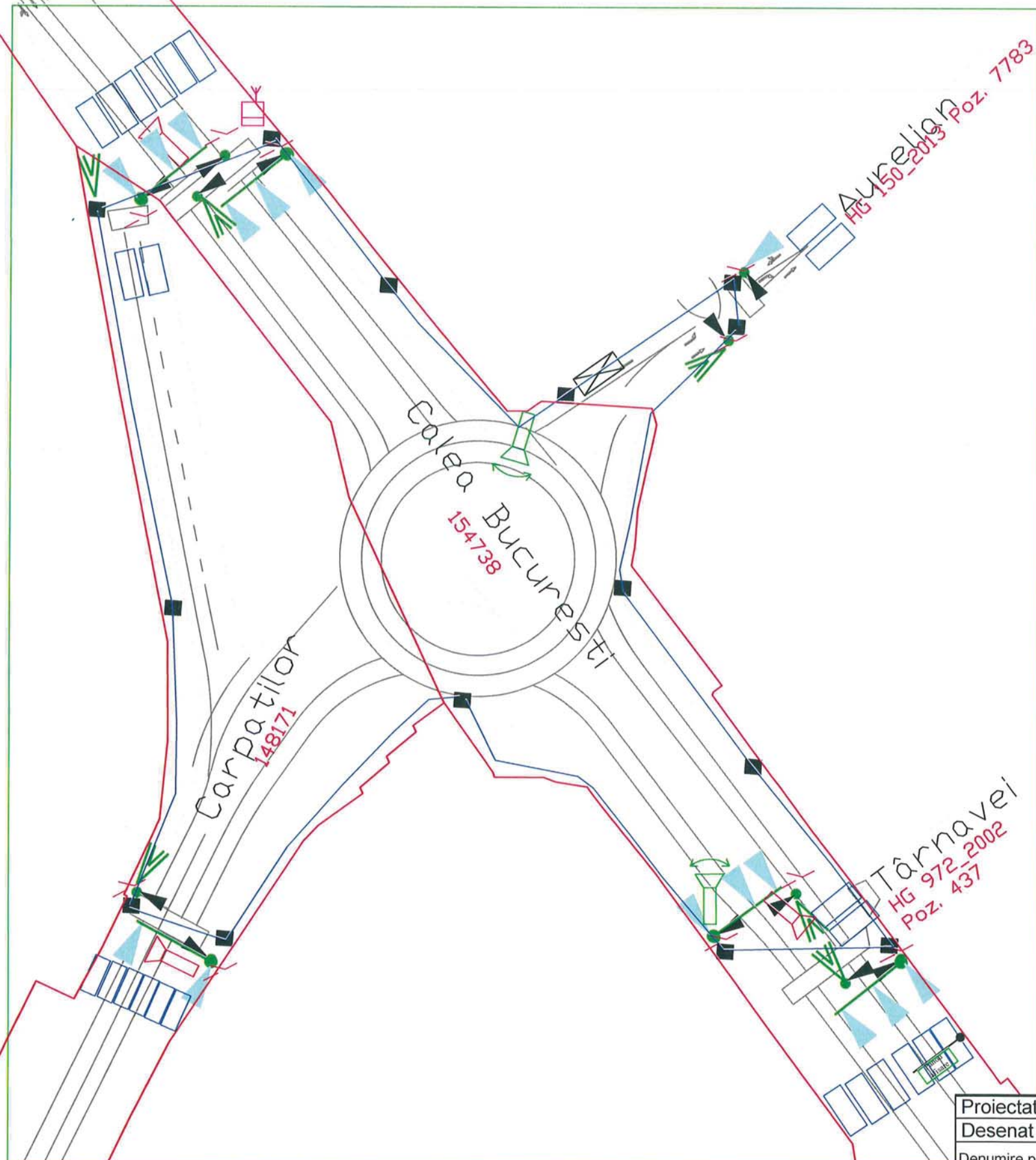

- LEGENDA:
- semafor vehicule
 - semafor pietoni
 - VID/GIP
 - buton semafor pietoni
 - zona detectie video
 - camera video fixa
 - camera video mobila
 - ADC
 - stalp
 - consola semafor
 - camereta de tragere
 - sapatura fibra optica
 - detector vehicul oprit
 - Dispozitiv radio LoRa
 - zona studiata
 - limita imobile
 - Panou afisare



Proiectat	M. Grigore		Verificat	V. Stan		Aprobat	V. Stan	
Desenat	M. Grigore		Data	octombrie 2018		Scara		
Denumire proiect:				PLAN DE SITUATIE				Faza:
"Sistem centralizat de monitorizare si control al traficului in Municipiul Brasov"				Semaforizare intersectie Calea Bucuresti-str. Carpatilor- str. Aurelian; str. Tarnavei				SF
Proiectant:				Nr. desen:				
SC AM PROJECT DESIGN & CONSULTING SRL				246/71723-2208-SF-05				A3

SF 06: Harmanului-Al Vlahuta-Garii

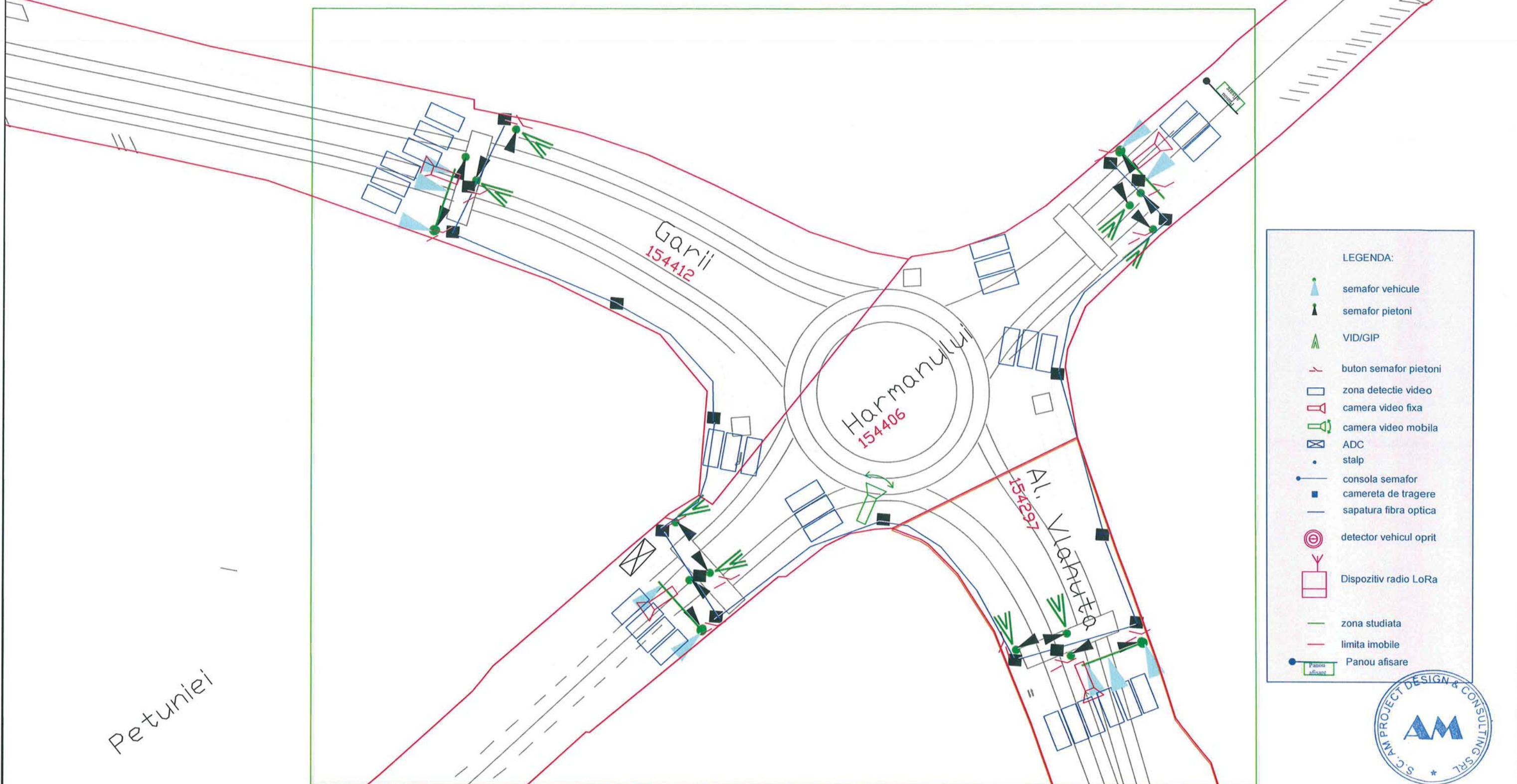

- LEGENDA:
- semafor vehicule
 - semafor pietoni
 - VID/GIP
 - buton semafor pietoni
 - zona detectie video
 - camera video fixa
 - camera video mobila
 - ADC
 - stalp
 - consola semafor
 - camera de tragere
 - sapatura fibra optica
 - detector vehicul oprit
 - Dispozitiv radio LoRa
 - zona studiata
 - limita imobile
 - Panou afisare



Proiectat	M. Grigore	Verificat	V. Stan	Aprobat	V. Stan
Desenat	M. Grigore	Data	octombrie 2018	Scara	
Denumire proiect: "Sistem centralizat de monitorizare si control al traficului in Municipiul Brasov"			PLAN DE SITUATIE Semaforizare intersectie str. Harmanului-Bd. Vlahuta-Bd. Garji		Faza: SF
Proiectant: SC AM PROJECT DESIGN & CONSULTING SRL			Nr. desen: 246/71723-2208-SF-06		A3

Mimo

SF 07: Zizinului-Al.Vlahuta-Saturn

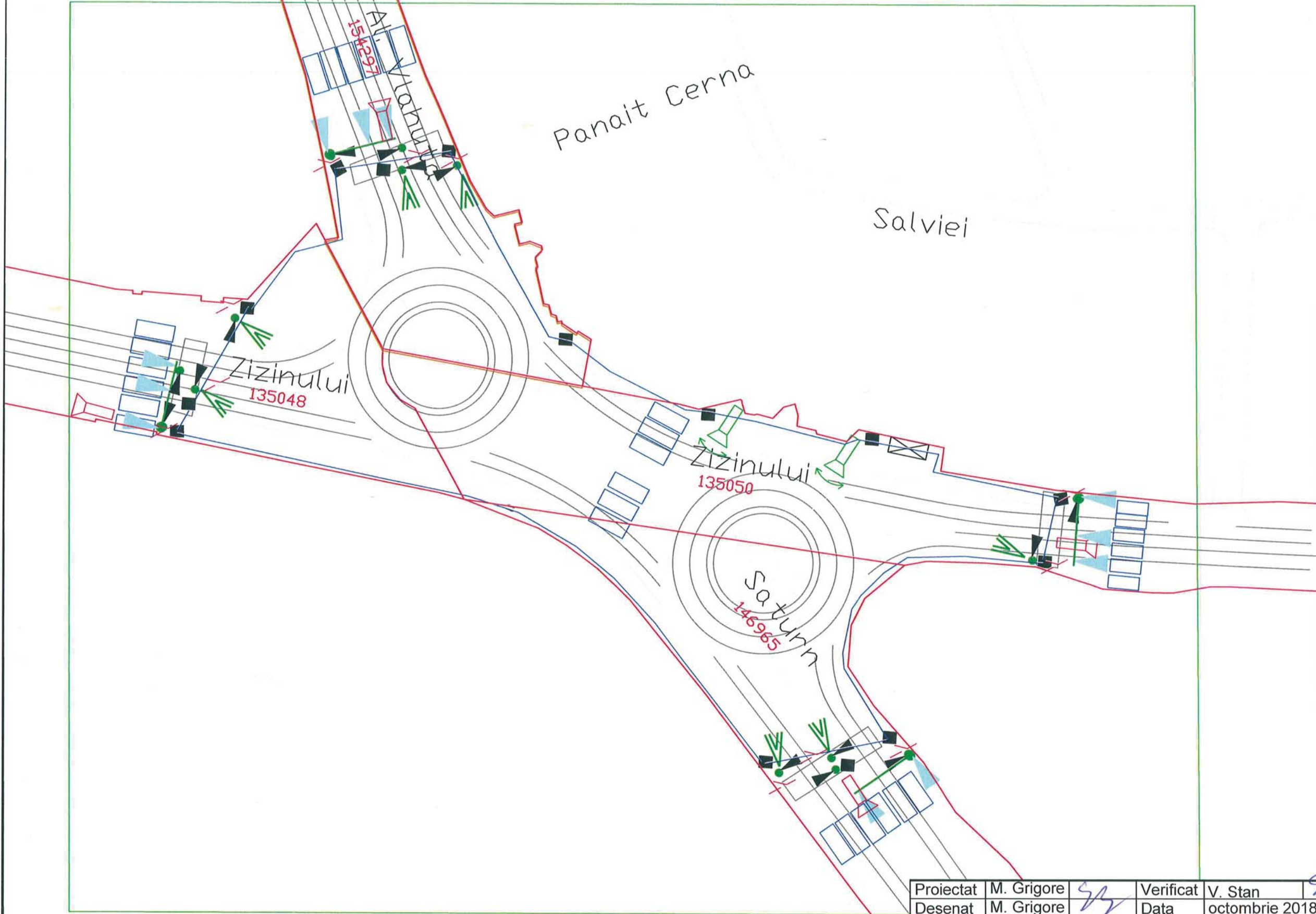

LEGENDA:

- semafor vehicule
- semafor pietoni
- VID/GIP
- buton semafor pietoni
- zona detectie video
- camera video fixa
- camera video mobila
- ADC
- stalp
- consola semafor
- camereta de tragere
- sapatura fibra optica
- detector vehicul oprit
- Dispozitiv radio LoRa
- zona studziata
- limita imobile
- Panou afisare



Proiectat	M. Grigore	Verificat	V. Stan	Aprobat	V. Stan
Desenat	M. Grigore	Data	octombrie 2018	Scara	
Denumire proiect: "Sistem centralizat de monitorizare si control al traficului in Municipiul Brasov"			PLAN DE SITUATIE Semaforizare intersectie str. Zizinului-Bd. Vlahuta-Bd. Saturn		Faza: SF
Proiectant: SC AM PROJECT DESIGN & CONSULTING SRL			Nr. desen: 246/71723-2208-SF-07		A3

SF 08: Carpatilor-Zorilor

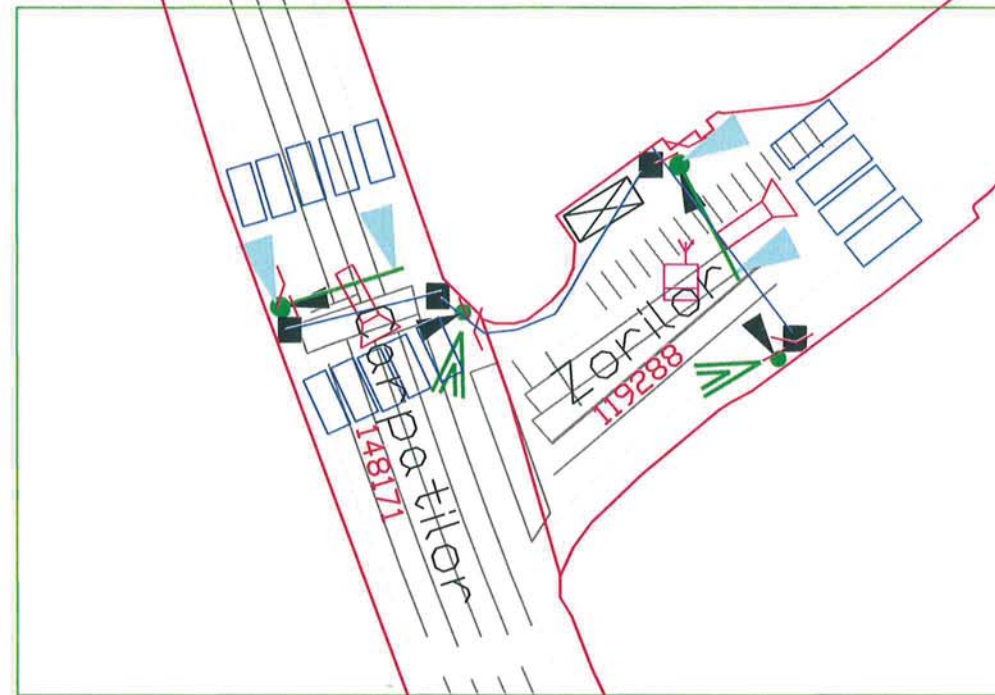

LEGENDA:

- semafor vehicule
- semafor pietoni
- VID/GIP
- buton semafor pietoni
- zona detectie video
- camera video fixa
- camera video mobila
- ADC
- stalp
- consola semafor
- camera de tragere
- sapatura fibra optica
- detector vehicul oprit
- Dispozitiv radio LoRa
- zona studiata
- limita imobile
- Panou afisare



Proiectat	M. Grigore	Verificat	V. Stan	Aprobat	V. Stan
Desenat	M. Grigore	Data	octombrie 2018	Scara	
Denumire proiect: "Sistem centralizat de monitorizare si control al traficului in Municipiul Brasov"			PLAN DE SITUATIE Semaforizare intersectie str. Carpatilor-str. Zorilor		Faza: SF
Proiectant: SC AM PROJECT DESIGN & CONSULTING SRL			Nr. desen: 246/71723-2208-SF-08		A3

SF 09: Carpatilor - V Alecsandri

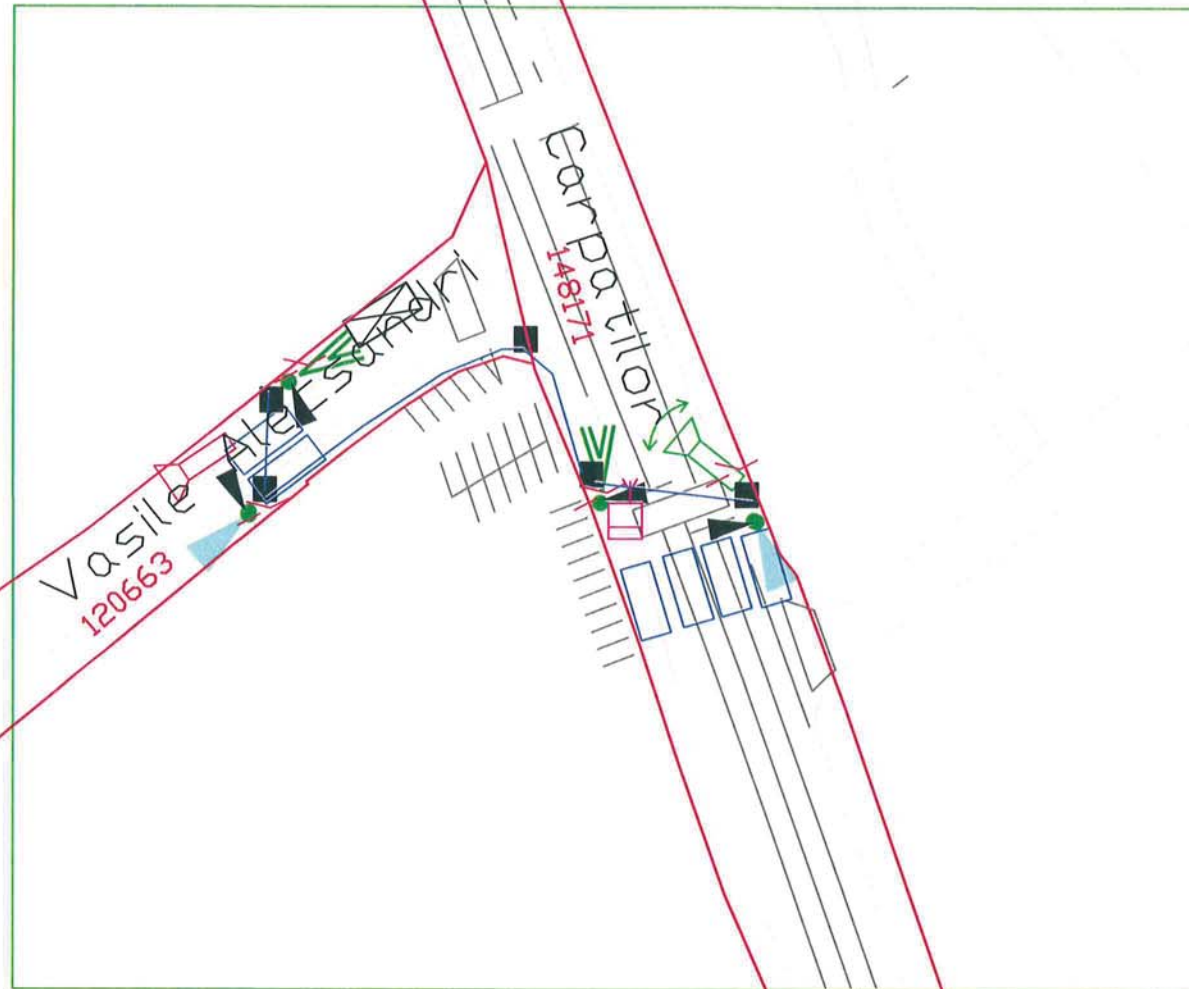

LEGENDA:

- semafor vehicule
- semafor pietoni
- VID/GIP
- buton semafor pietoni
- zona detectie video
- camera video fixa
- camera video mobila
- ADC
- stalp
- consola semafor
- camereta de tragere
- sapatura fibra optica
- detector vehicul oprit
- Dispozitiv radio LoRa
- zona studiata
- limita imobile
- Panou afisare



Proiectat	M. Grigore	Verificat	V. Stan	Aprobat	V. Stan
Desenat	M. Grigore	Data	octombrie 2018	Scara	
Denumire proiect: "Sistem centralizat de monitorizare si control al traficului in Municipiul Brasov"			PLAN DE SITUATIE Semaforizare intersectie str. Carpatilor-str. V Alecsandri		Faza: SF
Proiectant: SC AM PROJECT DESIGN & CONSULTING SRL			Nr. desen: 246/71723-2208-SF-09		A3

SF 08: C

SF 11.1: Kogalniceanu - Grivitei

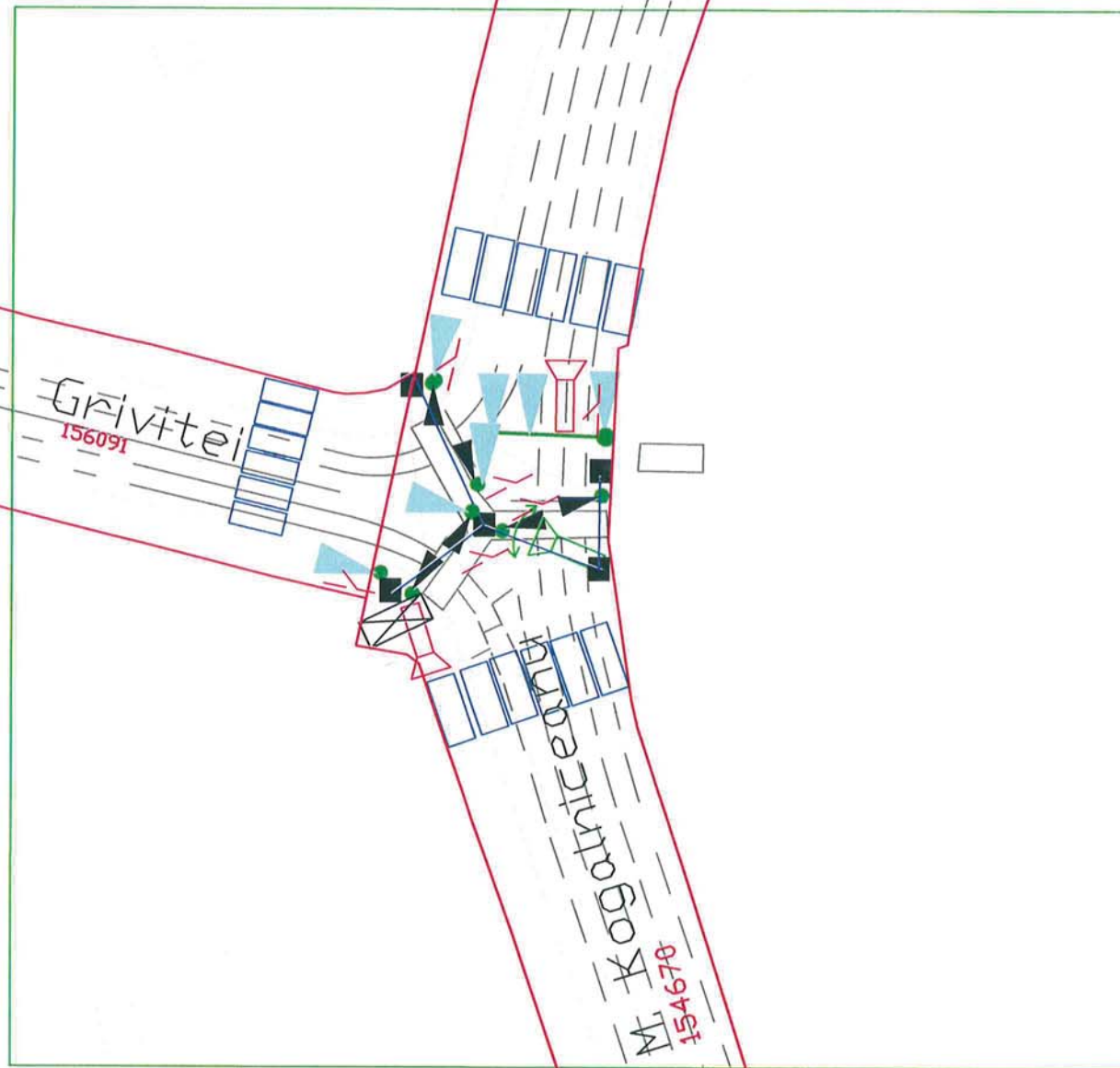

LEGENDA:

-  semafor vehicule
-  semafor pietoni
-  VID/GIP
-  buton semafor pietoni
-  zona detectie video
-  camera video fixa
-  camera video mobila
-  ADC
-  stalp
-  consola semafor
-  camereta de tragere
-  sapatura fibra optica
-  detector vehicul oprit
-  Dispozitiv radio LoRa
-  zona studiata
-  limita imobile
-  Panou afisare



Proiectat	M. Grigore	Verificat	V. Stan	Aprobat	V. Stan
Desenat	M. Grigore	Data	octombrie 2018	Scara	
Denumire proiect: "Sistem centralizat de monitorizare si control al traficului in Municipiul Brasov"			PLAN DE SITUATIE Semaforizare intersectie str. M. Kogalniceanu-Bd. Grivitei		Faza: SF
Proiectant: SC AM PROJECT DESIGN & CONSULTING SRL			Nr. desen: 246/71723-2208-SF-11.1		A3

SF 11.2: Grivitei-13 Decembrie

9 Mai

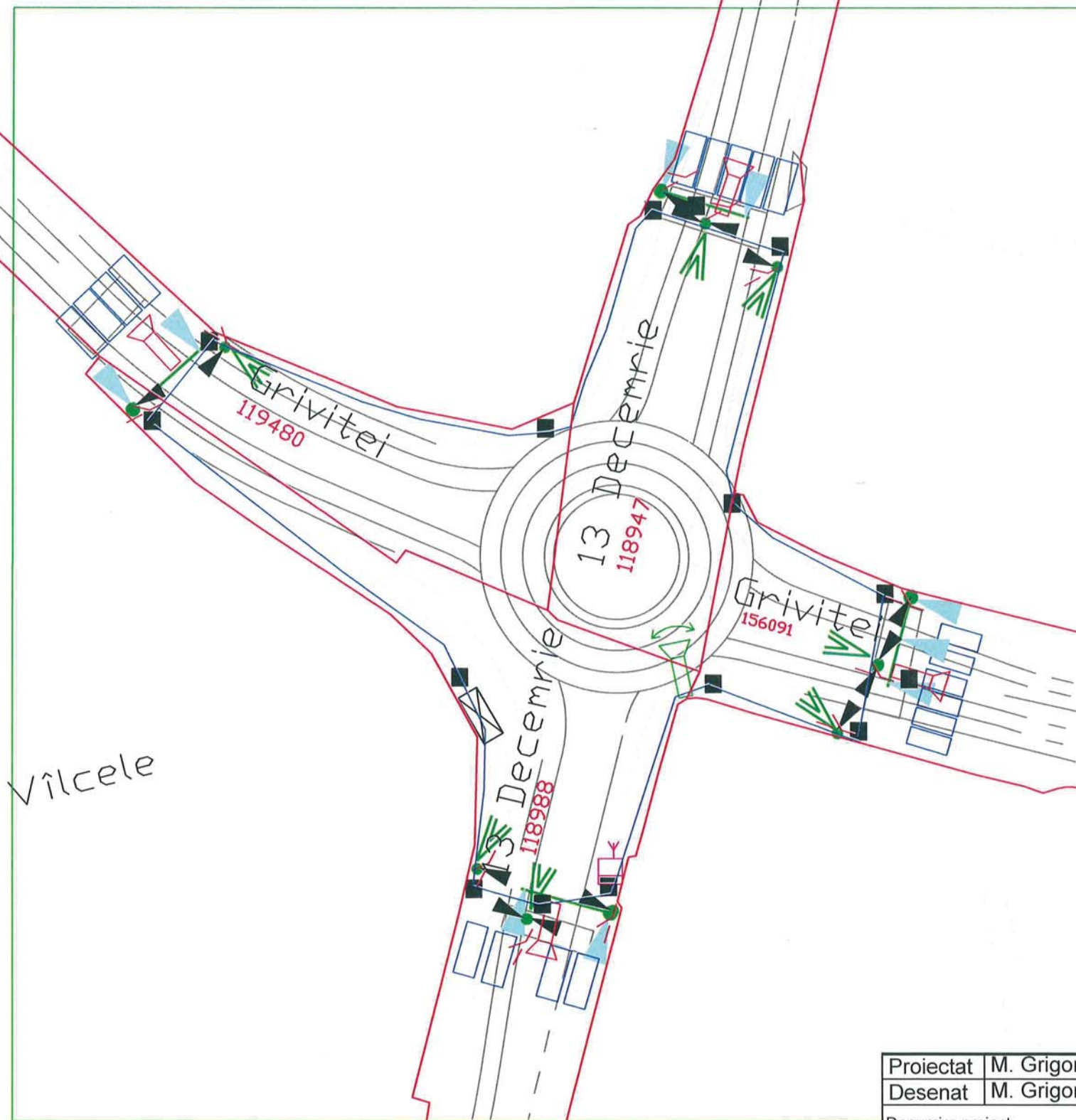

LEGENDA:

- semafor vehicule
- semafor pietoni
- VID/GIP
- buton semafor pietoni
- zona detectie video
- camera video fixa
- camera video mobila
- ADC
- stalp
- consola semafor
- camereta de tragere
- sapatura fibra optica
- detector vehicul oprit
- Dispozitiv radio LoRa
- zona studiata
- limita imobile
- Panou afisare

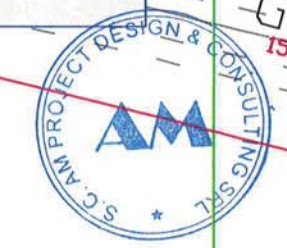

Proiectat	M. Grigore		Verificat	V. Stan		Aprobat	V. Stan	
Desenat	M. Grigore		Data	octombrie 2018		Scara		
Denumire proiect:				PLAN DE SITUATIE				Faza:
"Sistem centralizat de monitorizare si control al traficului in Municipiul Brasov"				Semaforizare intersectie Bd. Grivitei-str. 13 Decembrie				SF
Proiectant:				Nr. desen:				
SC AM PROJECT DESIGN & CONSULTING SRL				246/71723-2208-SF-11.2				A3

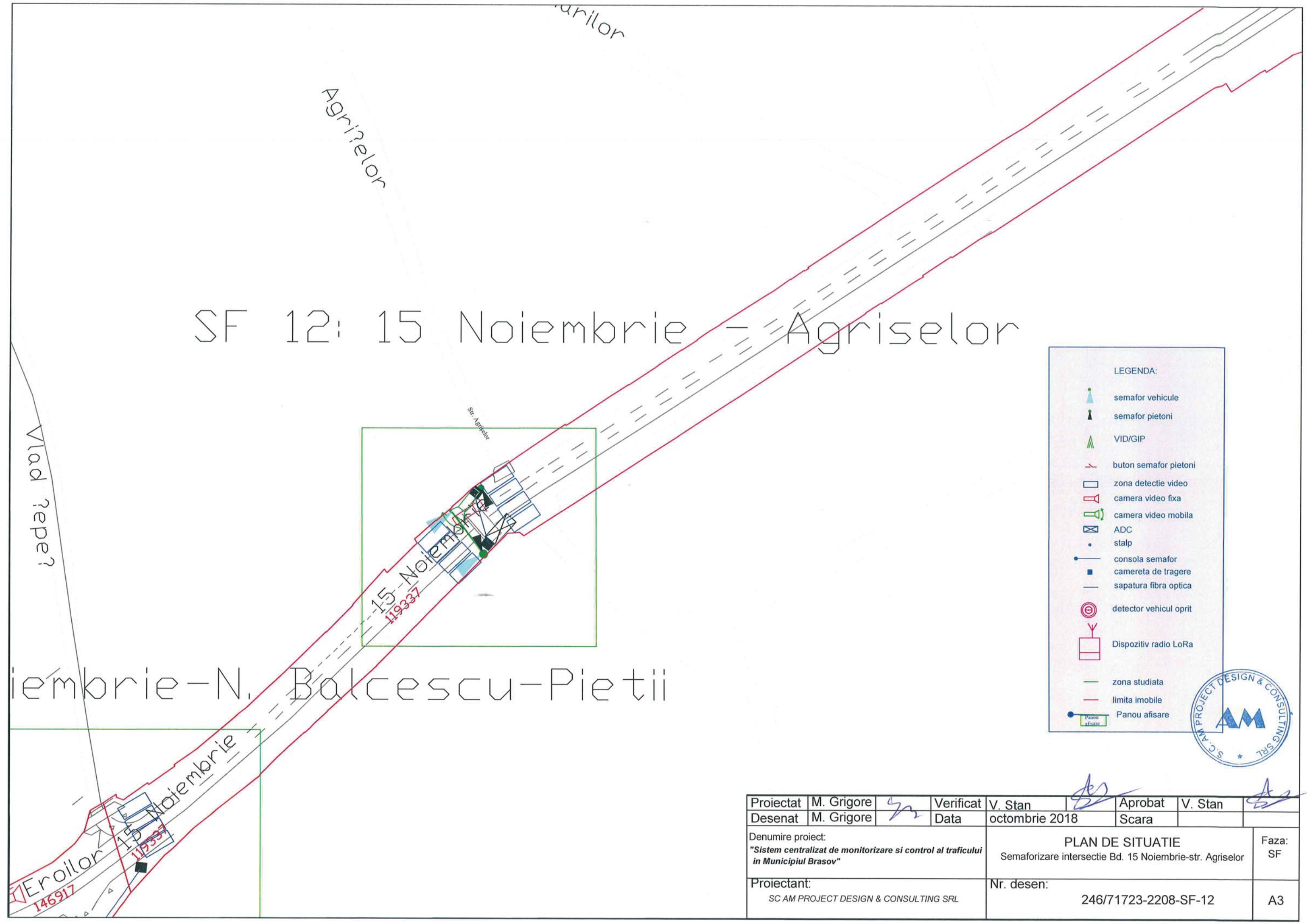

SF 12: 15 Noiembrie - Agriselor

- LEGENDA:
- semafor vehicule
 - semafor pietoni
 - VID/GIP
 - buton semafor pietoni
 - zona detectie video
 - camera video fixa
 - camera video mobila
 - ADC
 - stalp
 - consola semafor
 - camereta de tragere
 - sapatura fibra optica
 - detector vehicul oprit
 - Dispozitiv radio LoRa
 - zona studiată
 - limita imobile
 - Panou afisare



Proiectat	M. Grigore	Verificat	V. Stan	Aprobat	V. Stan
Desenat	M. Grigore	Data	octombrie 2018	Scara	
Denumire proiect: "Sistem centralizat de monitorizare si control al traficului in Municipiul Brasov"			PLAN DE SITUATIE Semaforizare intersecție Bd. 15 Noiembrie-str. Agriselor		Faza: SF
Proiectant: SC AM PROJECT DESIGN & CONSULTING SRL			Nr. desen:	246/71723-2208-SF-12	A3

SF 13.1: Eroilor-15 Noiembrie-N. Balcescu-Pietii

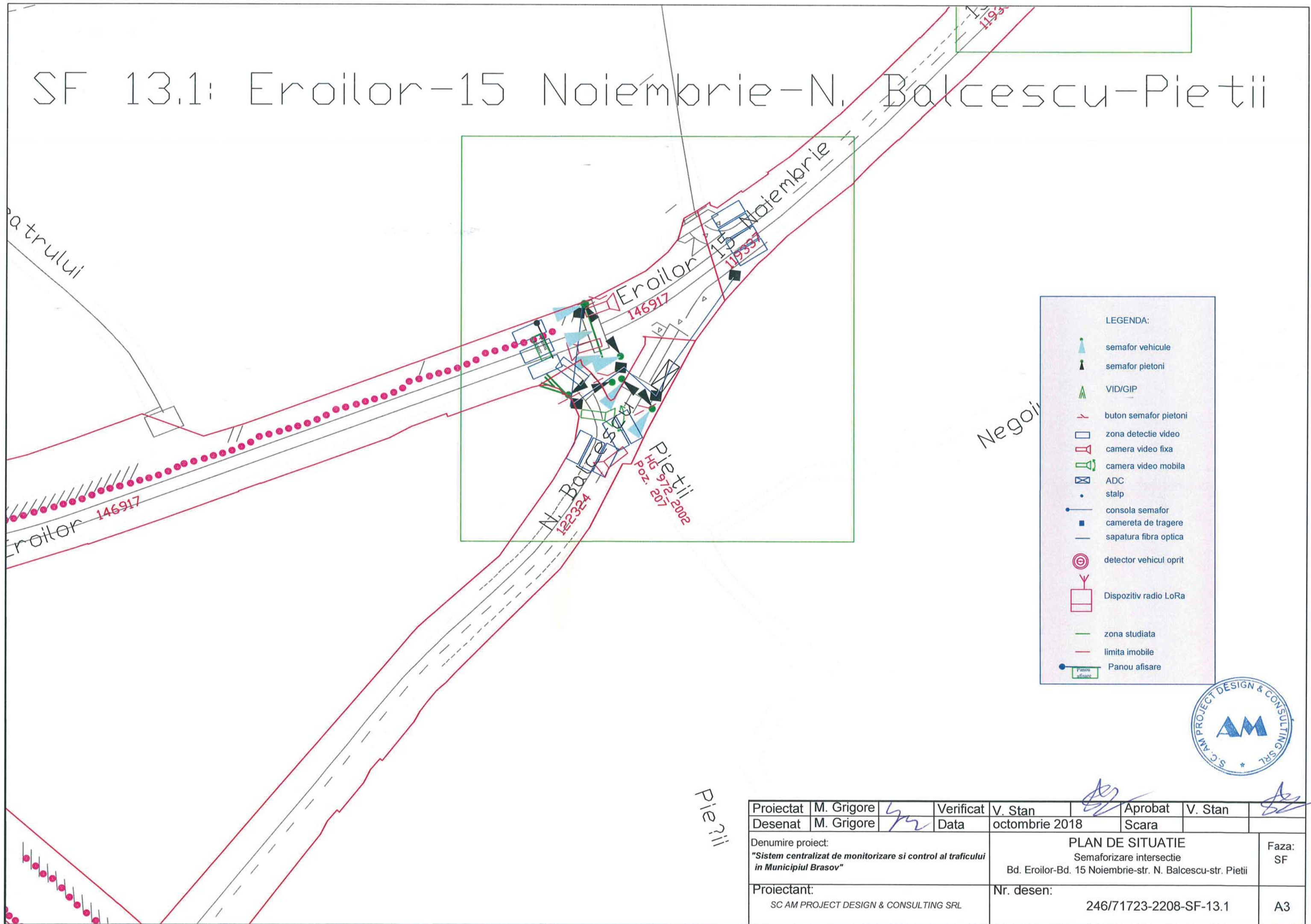

LEGENDA:

- semafor vehicule
- semafor pietoni
- VID/GIP
- buton semafor pietoni
- zona detectie video
- camera video fixa
- camera video mobila
- ADC
- stalp
- consola semafor
- camereta de tragere
- sapatura fibra optica
- detector vehicul oprit
- Dispozitiv radio LoRa
- zona studiata
- limita imobile
- Panou afisare



Proiectat	M. Grigore		Verificat	V. Stan		Aprobat	V. Stan	
Desenat	M. Grigore		Data	octombrie 2018		Scara		
Denumire proiect:				PLAN DE SITUATIE				Faza:
"Sistem centralizat de monitorizare si control al traficului in Municipiul Brasov"				Semaforizare intersectie				SF
				Bd. Eroilor-Bd. 15 Noiembrie-str. N. Balcescu-str. Pietii				
Proiectant:				Nr. desen:				
SC AM PROJECT DESIGN & CONSULTING SRL				246/71723-2208-SF-13.1				A3

SF 13.2: Eroilor - Lunga

SF 30: Eroilor - Sfântul

SF 29: Muresenilor - Sfântul

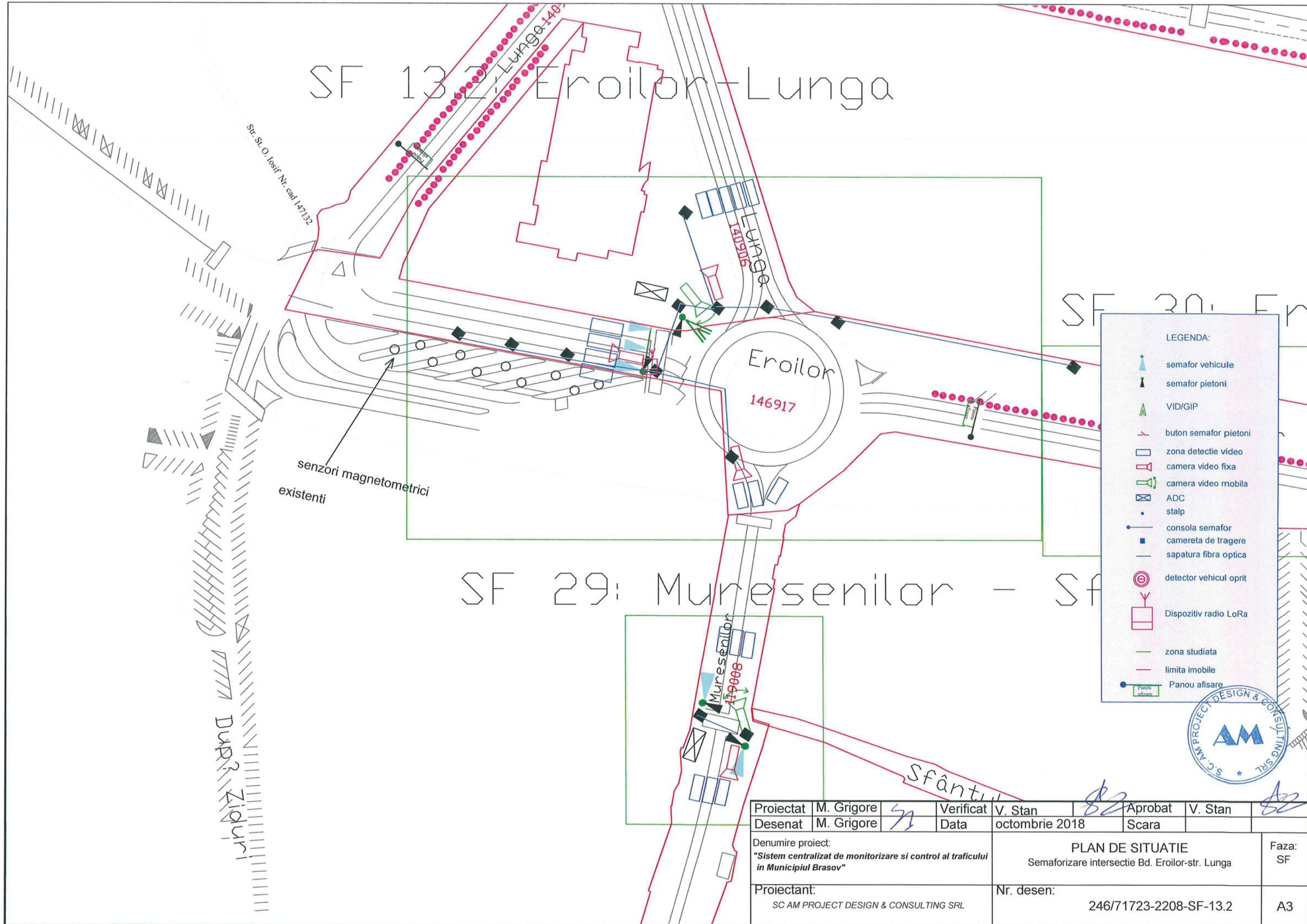

- LEGENDA:
- semafor vehicule
 - semafor pietoni
 - VID/GIP
 - buton semafor pietoni
 - zona detectie video
 - camera video fixa
 - camera video mobila
 - ADC
 - stalp
 - consola semafor
 - camera de tragere
 - sapatura fibra optica
 - detector vehicul oprit
 - Dispozitiv radio LoRa
 - zona studziata
 - limita imobile
 - Panou afisare



Proiectat	M. Grigore	Verificat	V. Stan	Aprobat	V. Stan
Desenat	M. Grigore	Data	octombrie 2018	Scara	
Denumire proiect: "Sistem centralizat de monitorizare si control al traficului in Municipiul Brasov"			PLAN DE SITUATIE Semaforizare intersectie Bd. Eroilor-str. Lunga		Faza: SF
Proiectant: SC AM PROJECT DESIGN & CONSULTING SRL			Nr. desen:	246/71723-2208-SF-13.2	A3

SF 13.3: Eroilor-N. Iorga

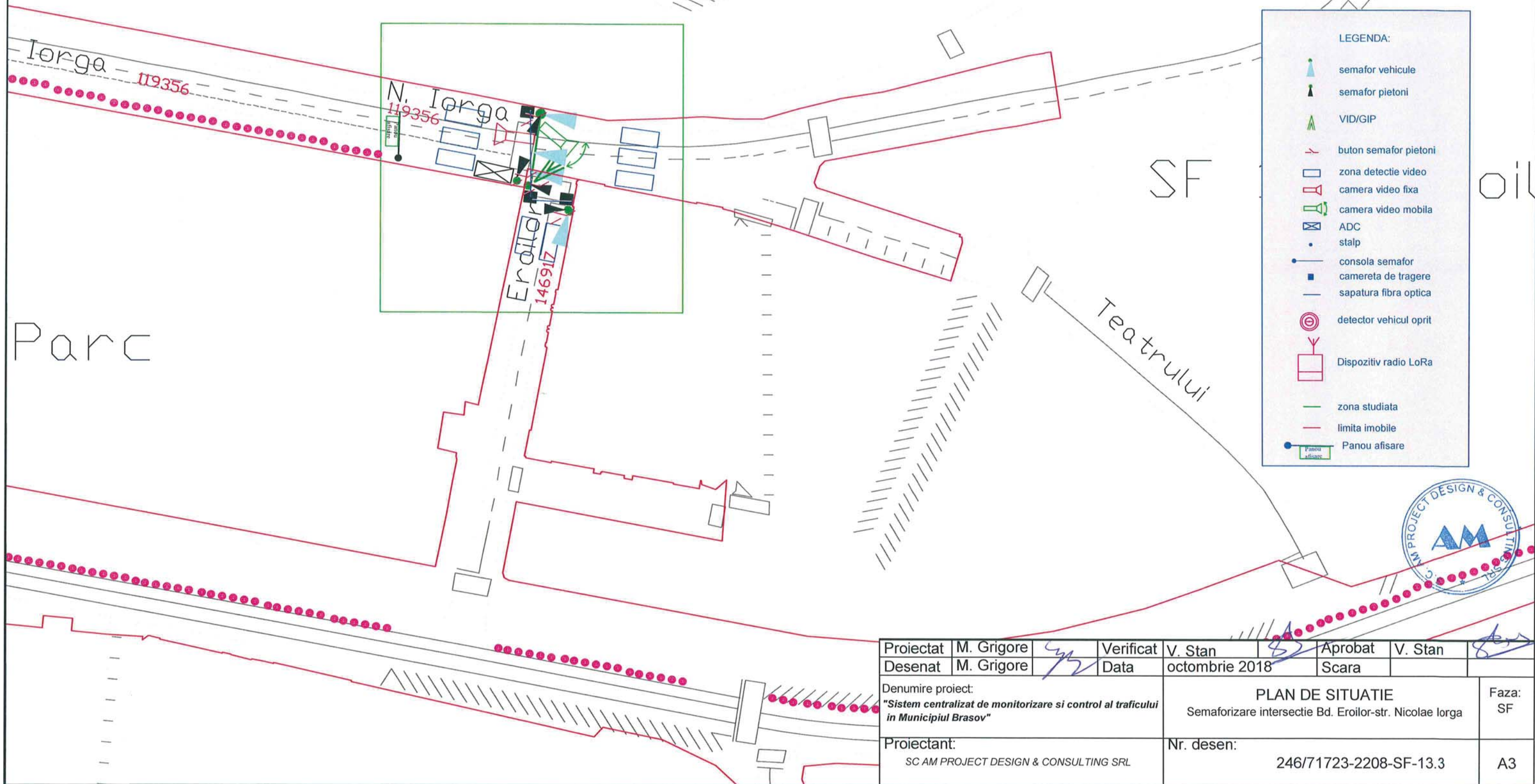

LEGENDA:

- semafor vehicule
- semafor pietoni
- VID/GIP
- buton semafor pietoni
- zona detectie video
- camera video fixa
- camera video mobila
- ADC
- stalp
- consola semafor
- camereta de tragere
- sapatura fibra optica
- detector vehicul oprit
- Dispozitiv radio LoRa
- zona studiata
- limita imobile
- Panou afisare

Proiectat	M. Grigore	Verificat	V. Stan	Aprobat	V. Stan
Desenat	M. Grigore	Data	octombrie 2018	Scara	
Denumire proiect: "Sistem centralizat de monitorizare si control al traficului in Municipiul Brasov"			PLAN DE SITUATIE Semaforizare intersectie Bd. Eroilor-str. Nicolae Iorga		Faza: SF
Proiectant: SC AM PROJECT DESIGN & CONSULTING SRL			Nr. desen: 246/71723-2208-SF-13.3		A3

SF 14: Bd. Garii str. 13
 Decembrie - str. Aurel Vlaicu

Vasile Carlova

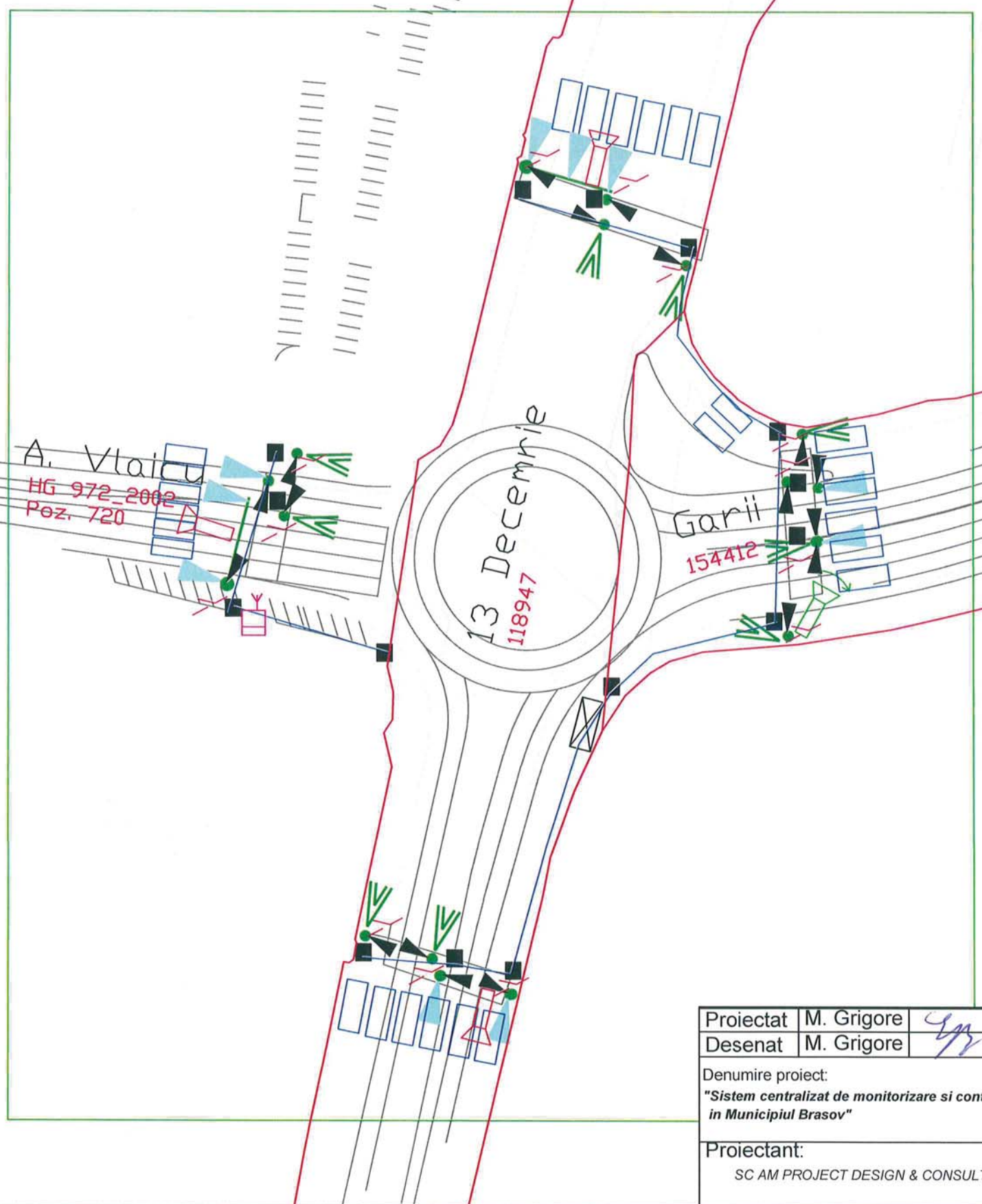

LEGENDA:

- semafor vehicule
- semafor pietoni
- VID/GIP
- buton semafor pietoni
- zona detectie video
- camera video fixa
- camera video mobila
- ADC
- stalp
- consola semafor
- camereta de tragere
- sapatura fibra optica
- detector vehicul oprit
- Dispozitiv radio LoRa
- zona studiată
- limita imobile
- Panou afisare



Proiectat	M. Grigore	Verificat	V. Stan	Aprobat	V. Stan
Desenat	M. Grigore	Data	octombrie 2018	Scara	
Denumire proiect: "Sistem centralizat de monitorizare si control al traficului in Municipiul Brasov"			PLAN DE SITUATIE Semaforizare intersectie Bd. Garii-str. 13 Decembrie-A. Vlaicu		Faza: SF
Proiectant: SC AM PROJECT DESIGN & CONSULTING SRL			Nr. desen:	246/71723-2208-SF-14	A3

eclu

SF 15: 13 Decembrie-Independentei-Turnului

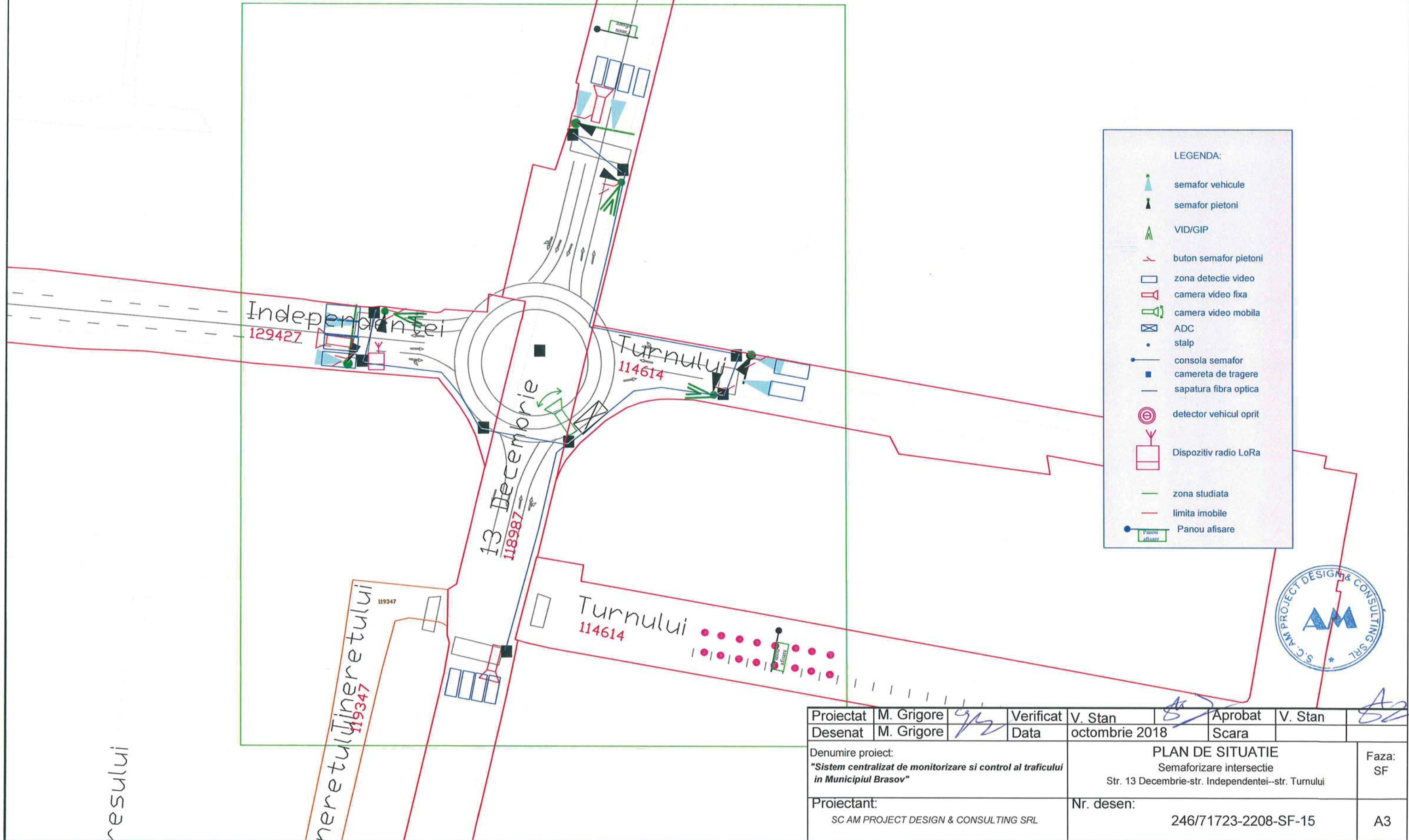

LEGENDA:

- semafor vehicule
- semafor pietoni
- VID/GIP
- buton semafor pietoni
- zona detectie video
- camera video fixa
- camera video mobila
- ADC
- stalp
- consola semafor
- camereta de tragere
- sapatura fibra optica
- detector vehicul oprit
- Dispozitiv radio LoRa
- zona studiata
- limita imobile
- Panou afisare



Proiectat	M. Grigore	Verificat	V. Stan	Aprobat	V. Stan	
Desenat	M. Grigore	Data	octombrie 2018	Scara		
Denumire proiect: "Sistem centralizat de monitorizare si control al traficului in Municipiul Brasov"			PLAN DE SITUATIE Semaforizare intersectie Str. 13 Decembrie-str. Independentei-str. Turnului		Faza: SF	
Proiectant: SC AM PROJECT DESIGN & CONSULTING SRL			Nr. desen: 246/71723-2208-SF-15		A3	

rezultul

SF 16: str.13 Decembrie-str.V. Goldis

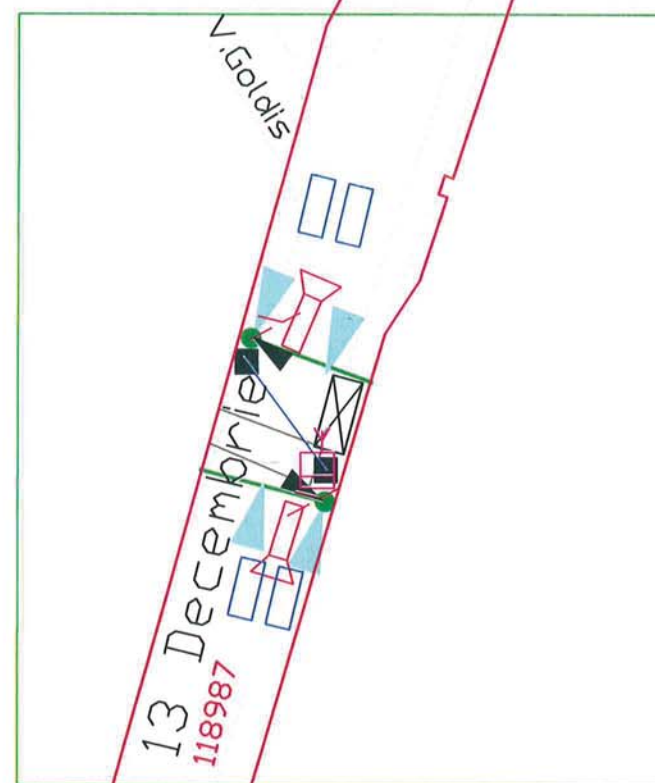

- LEGENDA:
- semafor vehicule
 - semafor pietoni
 - VID/GIP
 - buton semafor pietoni
 - zona detectie video
 - camera video fixa
 - camera video mobila
 - ADC
 - stalp
 - consola semafor
 - camereta de tragere
 - sapatura fibra optica
 - detector vehicul oprit
 - Dispozitiv radio LoRa
 - zona studiata
 - limita imobile
 - Panou afisare



Proiectat	M. Grigore	Verificat	V. Stan	Aprobat	V. Stan
Desenat	M. Grigore	Data	octombrie 2018	Scara	
Denumire proiect: "Sistem centralizat de monitorizare si control al traficului in Municipiul Brasov"			PLAN DE SITUATIE Semaforizare intersectie str. 13 Decembrie-str. Vasile Goldis		Faza: SF
Proiectant: SC AM PROJECT DESIGN & CONSULTING SRL			Nr. desen:	246/71723-2208-SF-16	A3

SF 17: A. Vlaicu-Grivitei-Plevnei

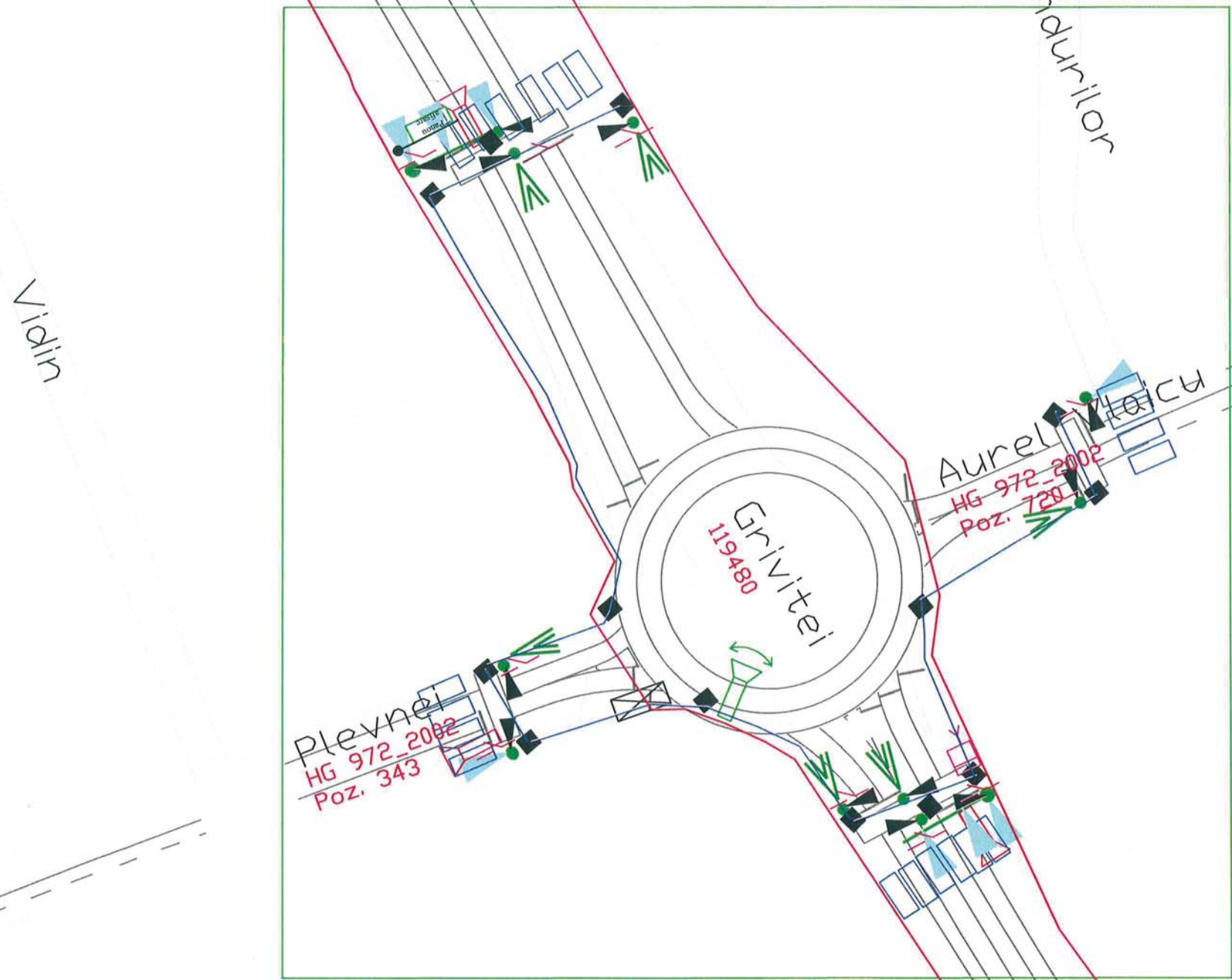

LEGENDA:

- semafor vehicule
- semafor pietoni
- VID/GIP
- buton semafor pietoni
- zona detectie video
- camera video fixa
- camera video mobila
- ADC
- stalp
- consola semafor
- camera de tragere
- sapatura fibra optica
- detector vehicul oprit
- Dispozitiv radio LoRa
- zona studiată
- limita imobile
- Panou afisare



1 Mai

Proiectat	M. Grigore	Verificat	V. Stan	Aprobat	V. Stan
Desenat	M. Grigore	Data	octombrie 2018	Scara	
Denumire proiect: "Sistem centralizat de monitorizare si control al traficului in Municipiul Brasov"			PLAN DE SITUATIE Semaforizare intersectie str. Aurel Vlaicu-Bd. Grivitei-str. Plevnei		Faza: SF
Proiectant: SC AM PROJECT DESIGN & CONSULTING SRL			Nr. desen: 246/71723-2208-SF-17		A3

116

SF 19.1: Zizinului-Lidl

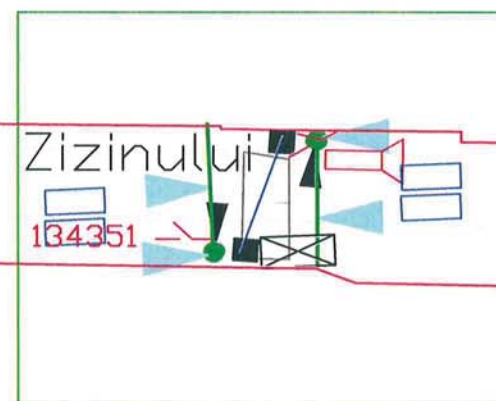

LEGENDA:

- semafor vehicule
- semafor pietoni
- VID/GIP
- buton semafor pietoni
- zona detectie video
- camera video fixa
- camera video mobila
- ADC
- stalp
- consola semafor
- camereta de tragere
- sapatura fibra optica
- detector vehicul oprit
- Dispozitiv radio LoRa
- zona studiata
- limita imobile
- Panou afisare



Proiectat	M. Grigore		Verificat	V. Stan		Aprobat	V. Stan	
Desenat	M. Grigore		Data	octombrie 2018		Scara		
Denumire proiect: "Sistem centralizat de monitorizare si control al traficului in Municipiul Brasov"				PLAN DE SITUATIE Semaforizare intersectie TP str. Zizinului-Lidl				Faza: SF
Proiectant: SC AM PROJECT DESIGN & CONSULTING SRL				Nr. desen: 246/71723-2208-SF-19.1				A3

SF 19.2: Zizinului nr 116

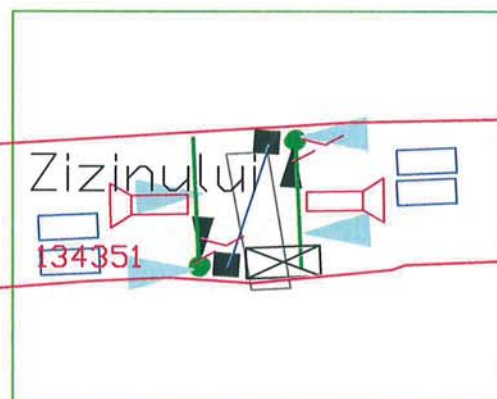

LEGENDA:

- semafor vehicule
- semafor pietoni
- VID/GIP
- buton semafor pietoni
- zona detectie video
- camera video fixa
- camera video mobila
- ADC
- stalp
- consola semafor
- camereta de tragere
- sapatura fibra optica
- detector vehicul oprit
- Dispozitiv radio LoRa
- zona studiată
- limita imobile
- Panou afisare

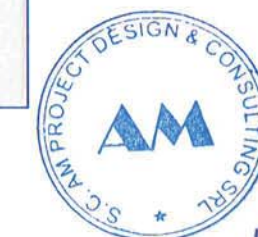

Proiectat	M. Grigore		Verificat	V. Stan		Aprobat	V. Stan	
Desenat	M. Grigore		Data	octombrie 2018		Scara		
Denumire proiect: "Sistem centralizat de monitorizare si control al traficului in Municipiul Brasov"				PLAN DE SITUATIE Semaforizare intersectie TP str. Zizinului nr. 116				Faza: SF
Proiectant: SC AM PROJECT DESIGN & CONSULTING SRL				Nr. desen: 246/71723-2208-SF-19.2				A3

SF 20: A.I. Cuza-Spital Marzescu

Dr. Alexandru

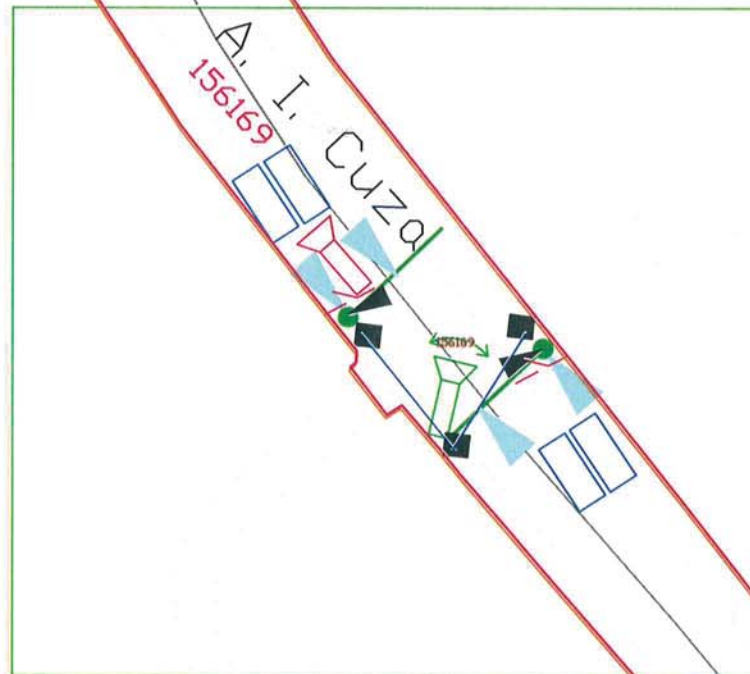

LEGENDA:

- semafor vehicule
- semafor pietoni
- VID/GIP
- buton semafor pietoni
- zona detectie video
- camera video fixa
- camera video mobila
- ADC
- stalp
- consola semafor
- camereta de tragere
- sapatura fibra optica
- detector vehicul oprit
- Dispozitiv radio LoRa
- zona studiata
- limita imobile
- Panou afisare

Bake?

Dr. Toma

Dr. Gheorghe Marinescu



Proiectat	M. Grigore	Verificat	V. Stan	Aprobat	V. Stan
Desenat	M. Grigore	Data	octombrie 2018	Scara	
Denumire proiect: "Sistem centralizat de monitorizare si control al traficului in Municipiul Brasov"			PLAN DE SITUATIE Semaforizare intersectie str. A.I. Cuza-Spital Marzescu		Faza: SF
Proiectant: SC AM PROJECT DESIGN & CONSULTING SRL			Nr. desen: 246/71723-2208-SF-20		A3

can?a

SF 22.1: Lunga-Stadionului-Fagarasului

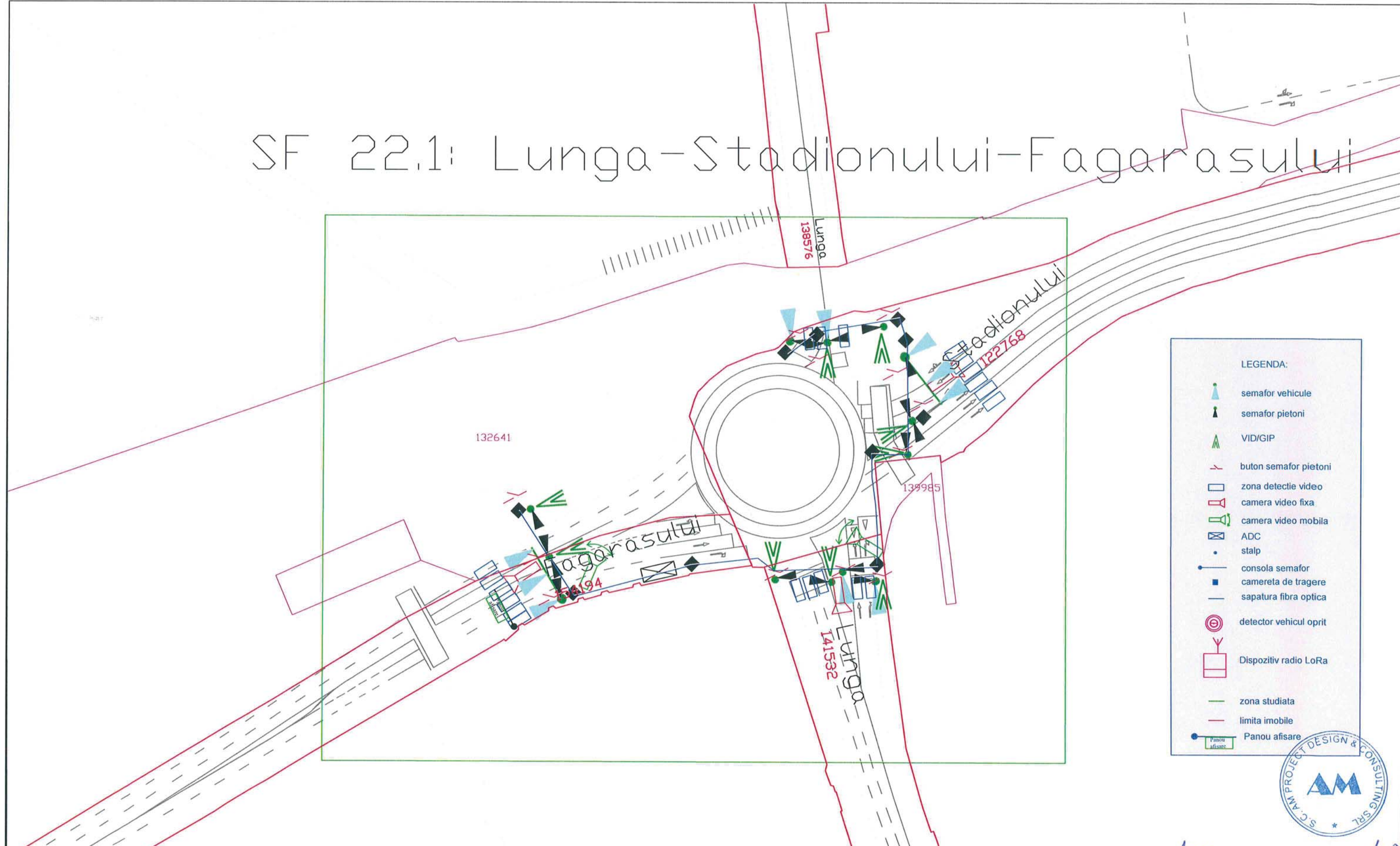

- LEGENDA:**
- semafor vehicule
 - semafor pietoni
 - VID/GIP
 - buton semafor pietoni
 - zona detectie video
 - camera video fixa
 - camera video mobila
 - ADC
 - stalp
 - consola semafor
 - camera de tragere
 - sapatura fibra optica
 - detector vehicul oprit
 - Dispozitiv radio LoRa
 - zona studiata
 - limita imobile
 - Panou afisare



Proiectat	M. Grigore	Verificat	V. Stan	Aprobat	V. Stan
Desenat	M. Grigore	Data	octombrie 2018	Scara	
Denumire proiect: "Sistem centralizat de monitorizare si control al traficului in Municipiul Brasov"			PLAN DE SITUATIE Semaforizare intersectie Str. Lunga-str. Stadionului-Calea Fagarasului		Faza: SF
Proiectant: SC AM PROJECT DESIGN & CONSULTING SRL			Nr. desen: 246/71723-2208-SF-22.1		A3

SF 22.2: Stadionului-M Viteazul

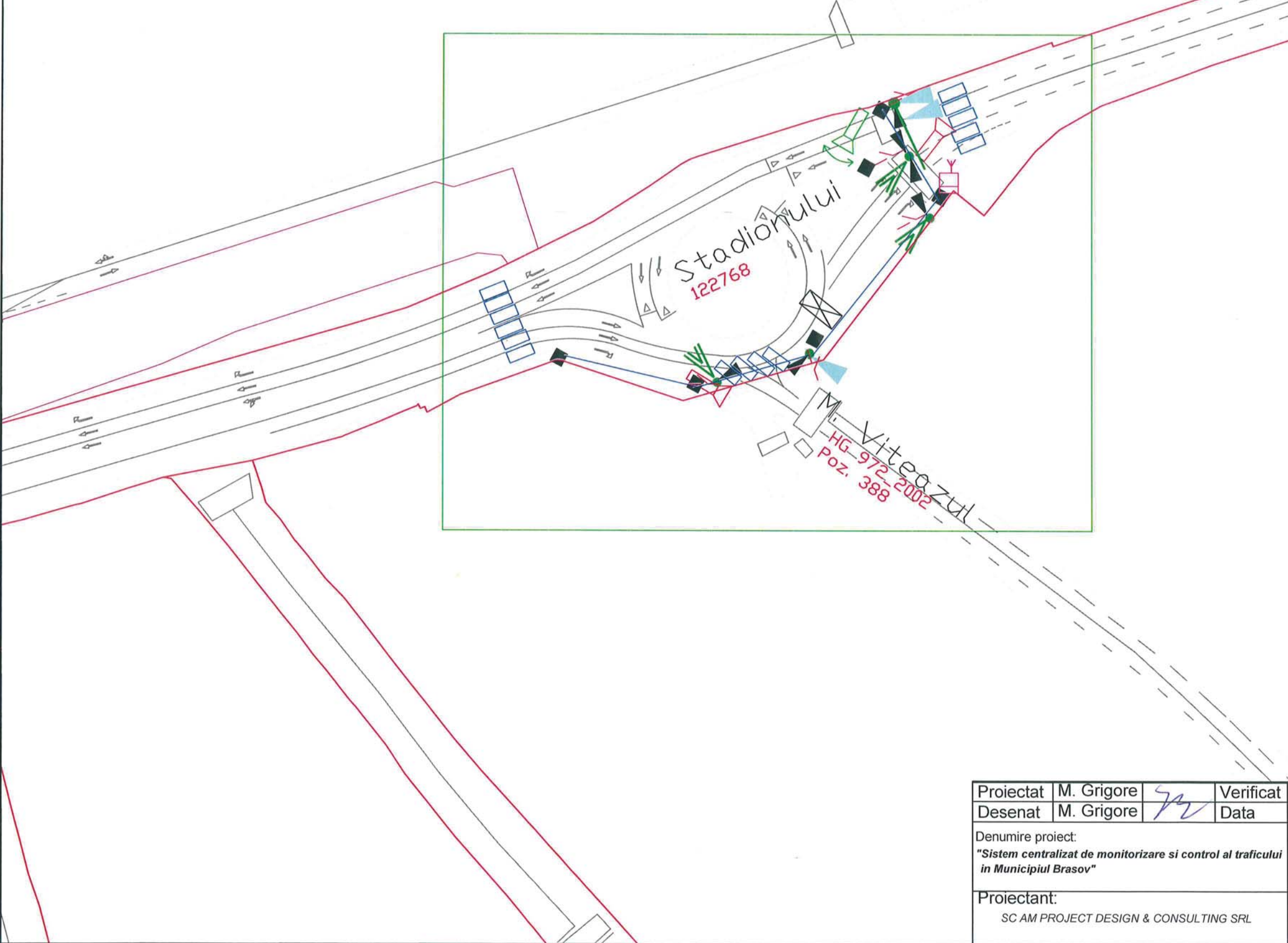

- LEGENDA:
- semafor vehicule
 - semafor pietoni
 - VID/GIP
 - buton semafor pietoni
 - zona detectie video
 - camera video fixa
 - camera video mobila
 - ADC
 - stalp
 - consola semafor
 - camereta de tragere
 - sapatura fibra optica
 - detector vehicul oprit
 - Dispozitiv radio LoRa
 - zona studiata
 - limita imobile
 - Panou afisare



Proiectat	M. Grigore		Verificat	V. Stan		Aprobat	V. Stan	
Desenat	M. Grigore		Data	octombrie 2018	Scara			
Denumire proiect:				PLAN DE SITUATIE				Faza:
"Sistem centralizat de monitorizare si control al traficului in Municipiul Brasov"				Semaforizare intersectie str. Stadionului-str. M. Viteazul				SF
Proiectant:				Nr. desen:				
SC AM PROJECT DESIGN & CONSULTING SRL				246/71723-2208-SF-22.2				A3

SF 23.1: Calea Fagarasului (OMV)-Sos. Cristianului

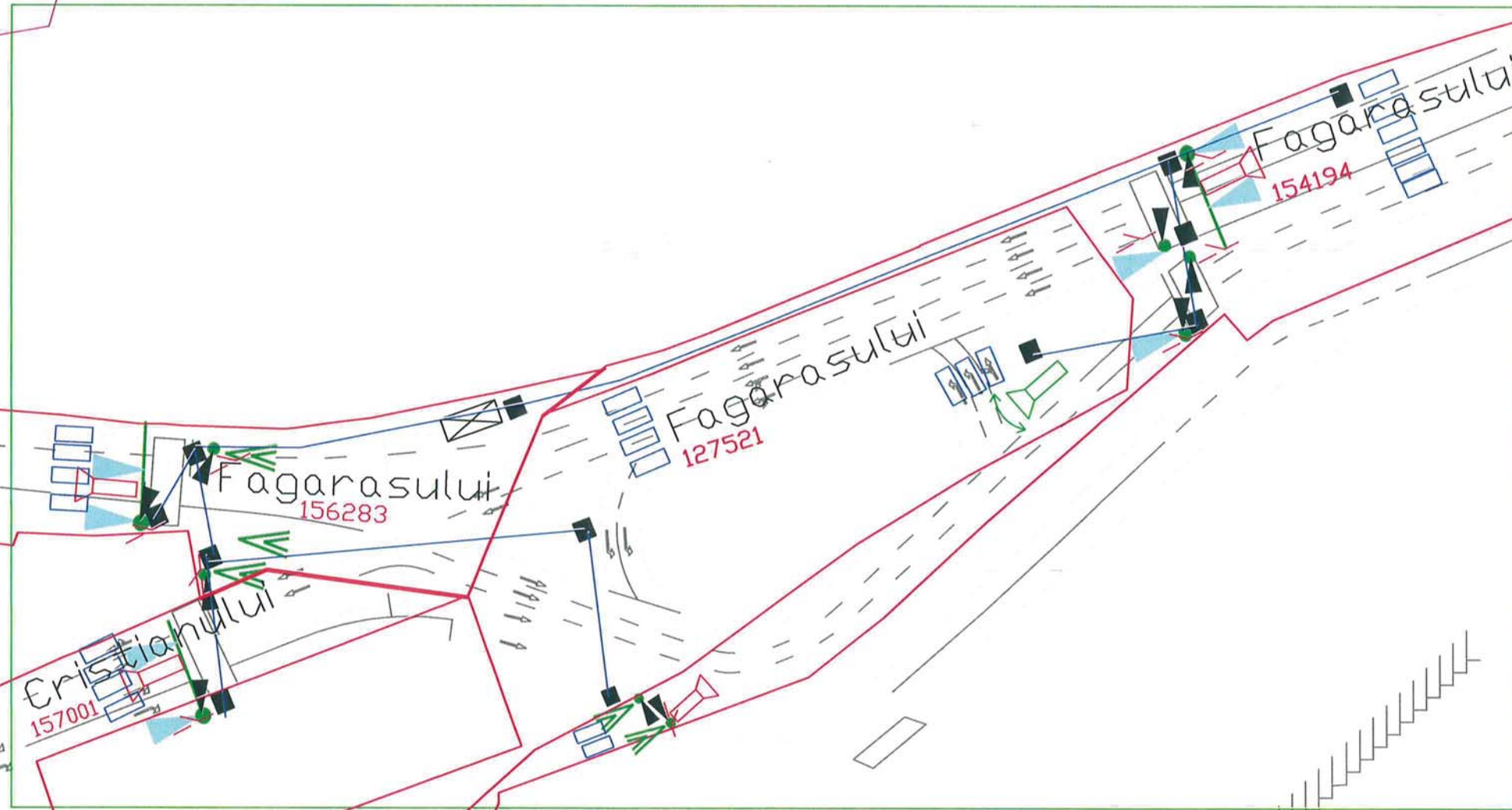

LEGENDA:

- semafor vehicule
- semafor pietoni
- VID/GIP
- buton semafor pietoni
- zona detectie video
- camera video fixa
- camera video mobila
- ADC
- stalp
- consola semafor
- camereta de tragere
- sapatura fibra optica
- detector vehicul oprit
- Dispozitiv radio LoRa
- zona studiata
- limita imobile
- Panou afisare



Proiectat	M. Grigore		Verificat	V. Stan		Aprobat	V. Stan	
Desenat	M. Grigore		Data	octombrie 2018		Scara		
Denumire proiect: "Sistem centralizat de monitorizare si control al traficului in Municipiul Brasov"				PLAN DE SITUATIE Semaforizare intersectie Calea Fagarasului (OMV)-Sos. Cristianului				Faza: SF
Proiectant: SC AM PROJECT DESIGN & CONSULTING SRL				Nr. desen: 246/71723-2208-SF-23.1				A3

SF 23.2: Sos. Cristianului (Brintex) - Str. Caramidariei

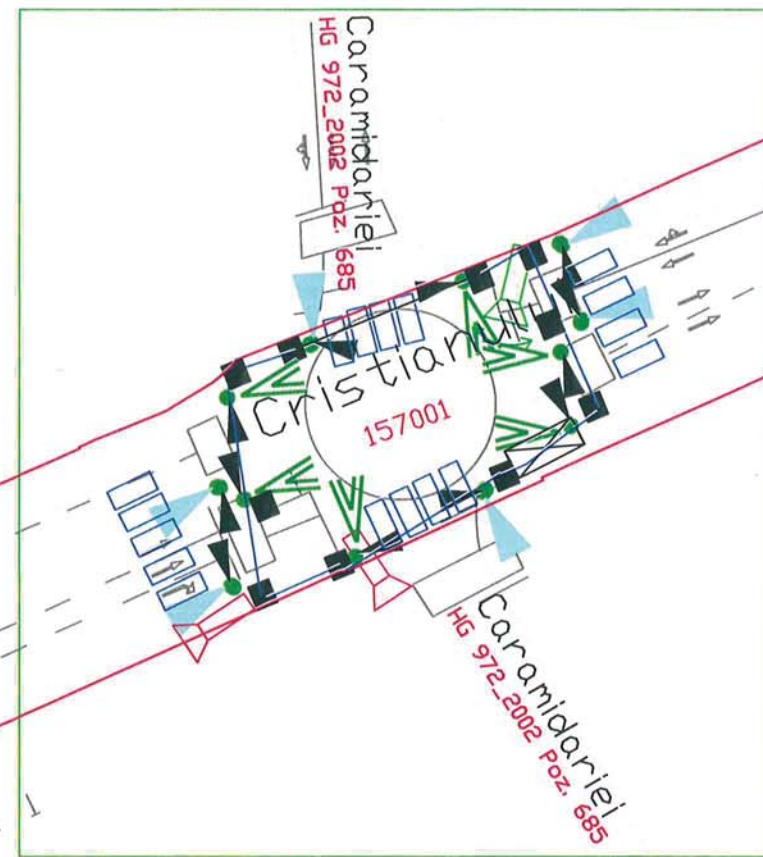

- LEGENDA:
- semafor vehicule
 - semafor pietoni
 - VID/GIP
 - buton semafor pietoni
 - zona detectie video
 - camera video fixa
 - camera video mobila
 - ADC
 - stalp
 - consola semafor
 - camereta de tragere
 - sapatura fibra optica
 - detector vehicul oprit
 - Dispozitiv radio LoRa
 - zona studziata
 - limita imobile
 - Panou afisare



Proiectat	M. Grigore	Verificat	V. Stan	Aprobat	V. Stan
Desenat	M. Grigore	Data	octombrie 2018	Scara	
Denumire proiect: "Sistem centralizat de monitorizare si control al traficului in Municipiul Brasov"			PLAN DE SITUATIE Semaforizare intersectie sos. Cristianului (Brintex)-str. Caramidariei		Faza: SF
Proiectant: SC AM PROJECT DESIGN & CONSULTING SRL			Nr. desen: 246/71723-2208-SF-23.2		A3

SF 24.1: Lunga - Memorandumului

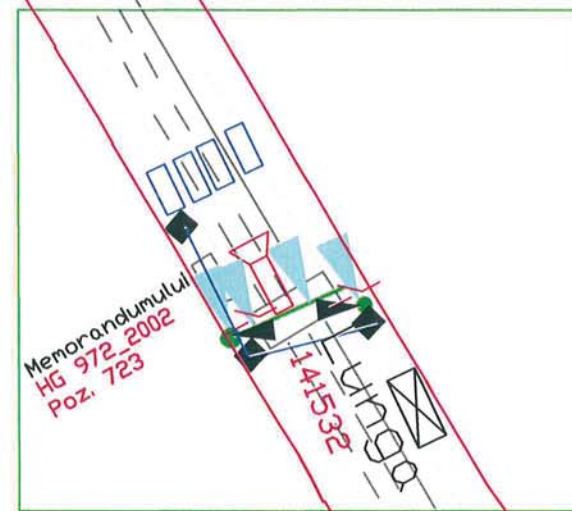

- LEGENDA:
- semafor vehicule
 - semafor pietoni
 - VID/GIP
 - buton semafor pietoni
 - zona detectie video
 - camera video fixa
 - camera video mobila
 - ADC
 - stalp
 - consola semafor
 - camereta de tragere
 - sapatura fibra optica
 - detector vehicul oprit
 - Dispozitiv radio LoRa
 - zona studiata
 - limita imobile
 - Panou afisare



Proiectat	M. Grigore	Verificat	V. Stan	Aprobat	V. Stan
Desenat	M. Grigore	Data	octombrie 2018	Scara	
Denumire proiect: "Sistem centralizat de monitorizare si control al traficului in Municipiul Brasov"			PLAN DE SITUATIE Semaforizare intersectie str. Lunga-str. Memorandumului		Faza: SF
Proiectant: SC AM PROJECT DESIGN & CONSULTING SRL			Nr. desen: 246/71723-2208-SF-24.1		A3

025

SF
Mijloc

SF 24.2 Lunga-Morii

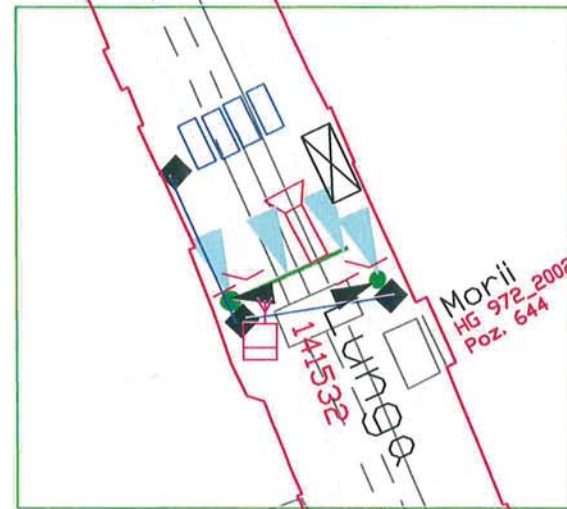

LEGENDA:

- semafor vehicule
- semafor pietoni
- VID/GIP
- buton semafor pietoni
- zona detectie video
- camera video fixa
- camera video mobila
- ADC
- stalp
- consola semafor
- camereta de tragere
- sapatura fibra optica
- detector vehicul oprit
- Dispozitiv radio LoRa
- zona studziata
- limita imobile
- Panou afisare



Proiectat	M. Grigore	Verificat	V. Stan	Aprobat	V. Stan
Desenat	M. Grigore	Data	octombrie 2018	Scara	
Denumire proiect: "Sistem centralizat de monitorizare si control al traficului in Municipiul Brasov"			PLAN DE SITUATIE Semaforizare intersectie str. Lunga-str. Morii		Faza: SF
Proiectant: SC AM PROJECT DESIGN & CONSULTING SRL			Nr. desen: 246/71723-2208-SF-24.2		A3

SF 24.3: Strada de Mijloc - str. Morii

a - Morii

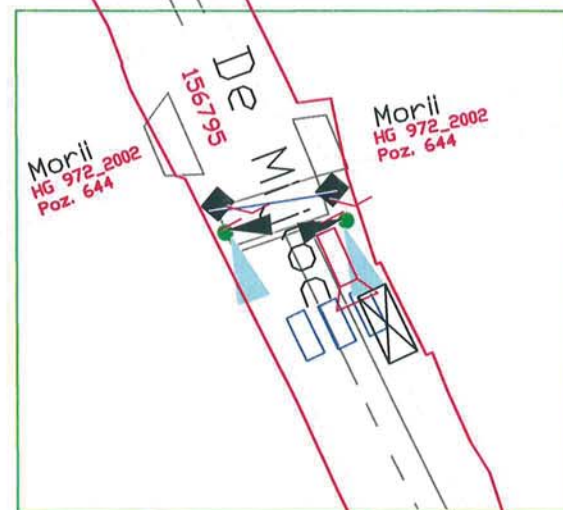

LEGENDA:

	semafor vehicule
	semafor pietoni
	VID/GIP
	buton semafor pietoni
	zona detectie video
	camera video fixa
	camera video mobilă
	ADC
	stalp
	consola semafor
	camereta de tragere
	sapatura fibra optica
	detector vehicul oprit
	Dispozitiv radio LoRa
	zona studiată
	limita imobile
	Panou afisare



Proiectat	M. Grigore	Verificat	V. Stan	Aprobat	V. Stan
Desenat	M. Grigore	Data	octombrie 2018	Scara	
Denumire proiect: "Sistem centralizat de monitorizare si control al traficului in Municipiul Brasov"			PLAN DE SITUATIE Semaforizare intersectie Strada de Mijloc-str. Morii		Faza: SF
Proiectant: SC AM PROJECT DESIGN & CONSULTING SRL			Nr. desen: 246/71723-2208-SF-24.3		A3

SF 24.4: Str. de Mijloc - Nicopole

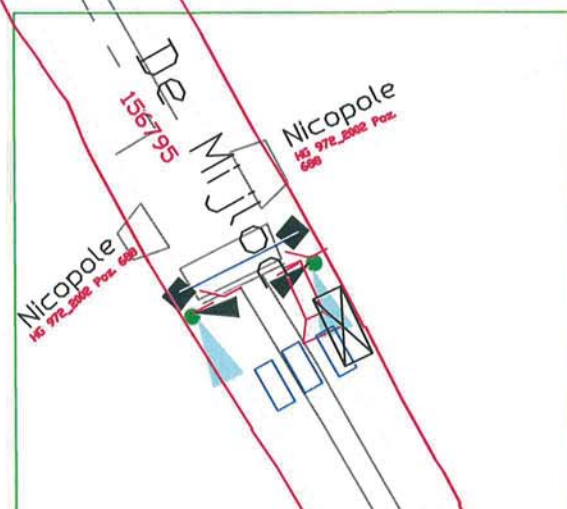

LEGENDA:

- semafor vehicule
- semafor pietoni
- VID/GIP
- buton semafor pietoni
- zona detectie video
- camera video fixa
- camera video mobila
- ADC
- stalp
- consola semafor
- camereta de tragere
- sapatura fibra optica
- detector vehicul oprit
- Dispozitiv radio LoRa
- zona studiata
- limita imobile
- Panou afisare



Proiectat	M. Grigore	Verificat	V. Stan	Aprobat	V. Stan
Desenat	M. Grigore	Data	octombrie 2018	Scara	
Denumire proiect: "Sistem centralizat de monitorizare si control al traficului in Municipiul Brasov"			PLAN DE SITUATIE Semaforizare intersectie Strada de Mijloc-str. Nicopole		Faza: SF
Proiectant: SC AM PROJECT DESIGN & CONSULTING SRL			Nr. desen: 246/71723-2208-SF-24.4		A3

SF 25: Str.A.Iancu - str. Bisericii Romane(fosta Operetei)

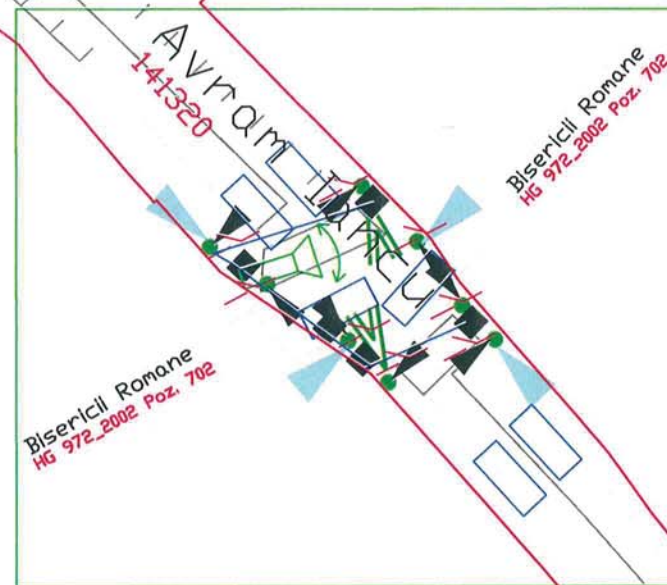

Proiectat	M. Grigore	Verificat	V. Stan	Aprobat	V. Stan
Desenat	M. Grigore	Data	octombrie 2018	Scara	
Denumire proiect: "Sistem centralizat de monitorizare si control al traficului in Municipiul Brasov"			PLAN DE SITUATIE Semaforizare intersectie Str.A.Iancu - str. Bisericii Romane (fosta Operetei)		Faza: SF
Proiectant: SC AM PROJECT DESIGN & CONSULTING SRL			Nr. desen: 246/71723-2208-SF-25		A3

Dr. Io

SF 26: Harmanului-Zaharia Stancu-Narciselor

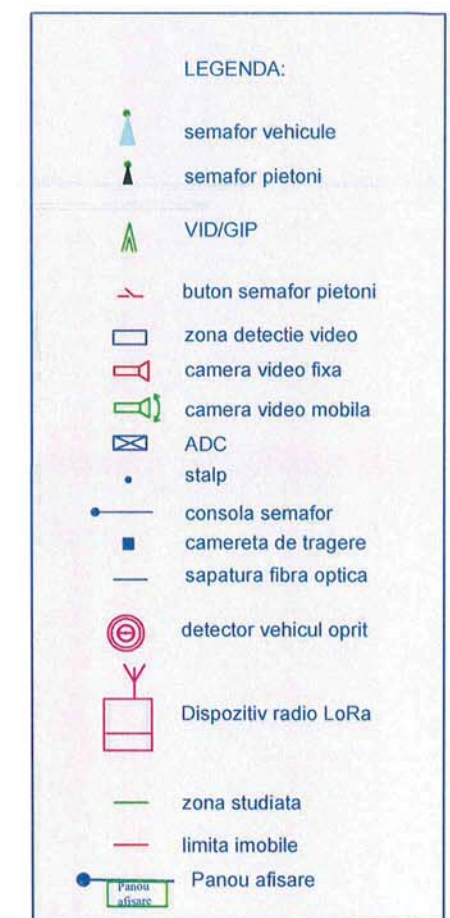
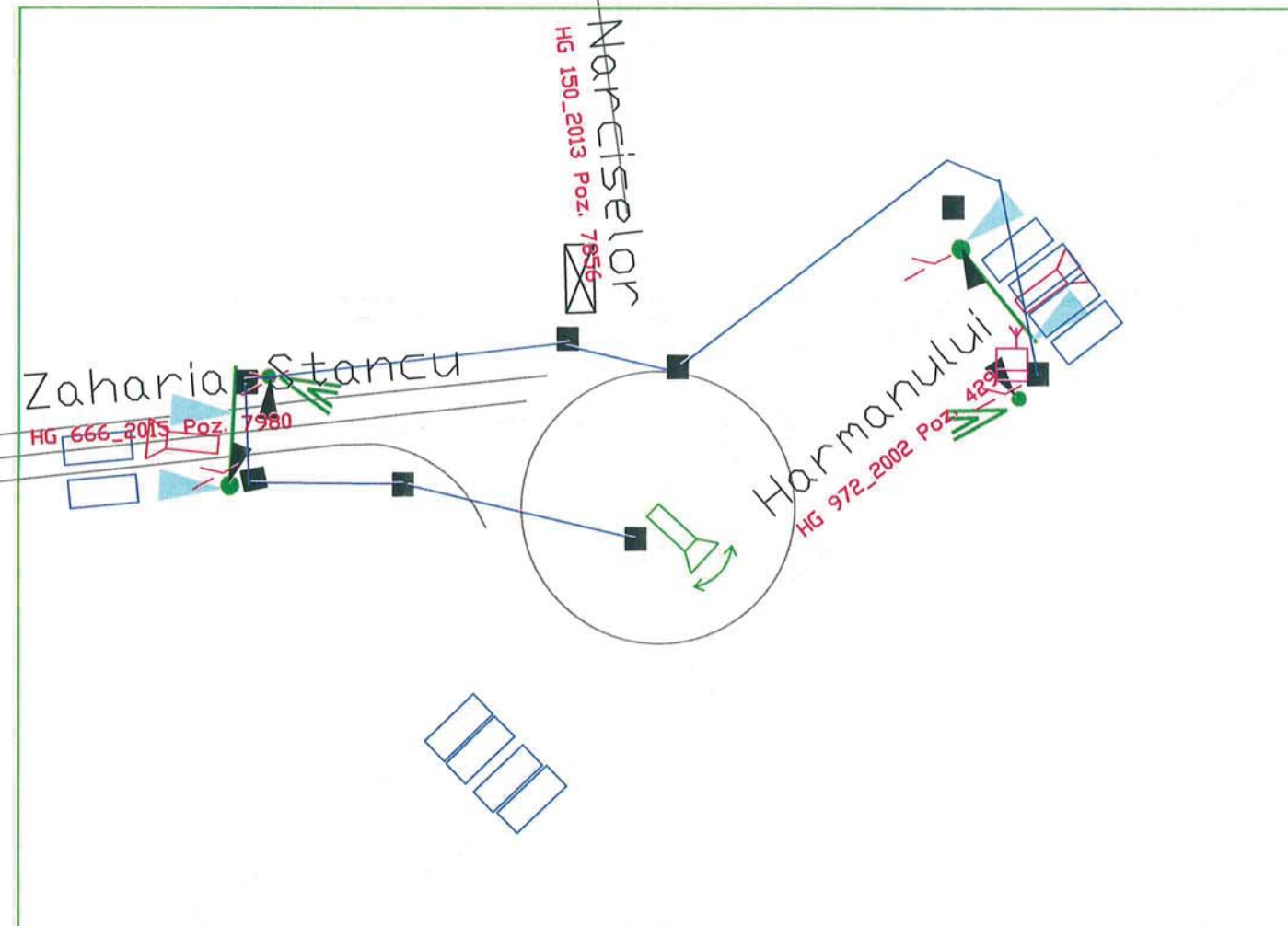

Proiectat	M. Grigore	Verificat	V. Stan	Aprobat	V. Stan
Desenat	M. Grigore	Data	octombrie 2018	Scara	
Denumire proiect: "Sistem centralizat de monitorizare si control al traficului in Municipiul Brasov"			PLAN DE SITUATIE Semaforizare intersectie Str. Harmanului-str. Zaharia Stancu-str. Narciselor		Faza: SF
Proiectant: SC AM PROJECT DESIGN & CONSULTING SRL			Nr. desen: 246/71723-2208-SF-26		A3

SF 27.1: Str. Valea Cetatii
str. Ghindei (Liceu)

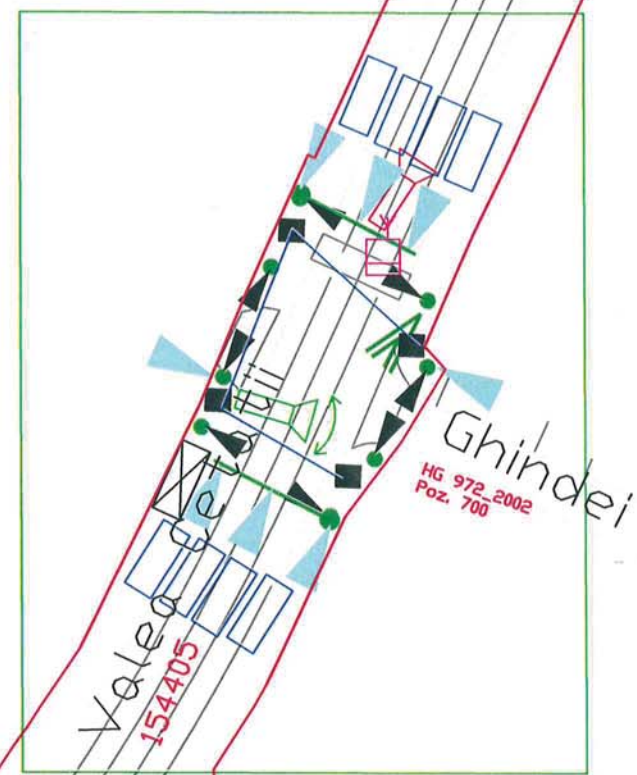

- LEGENDA:
- semafor vehicule
 - semafor pietoni
 - VID/GIP
 - buton semafor pietoni
 - zona detectie video
 - camera video fixa
 - camera video mobila
 - ADC
 - stalp
 - consola semafor
 - camereta de tragere
 - sapatura fibra optica
 - detector vehicul oprit
 - Dispozitiv radio LoRa
 - zona studiata
 - limita imobile
 - Panou afisare



Proiectat	M. Grigore	Verificat	V. Stan	Aprobat	V. Stan
Desenat	M. Grigore	Data	octombrie 2018	Scara	
Denumire proiect: "Sistem centralizat de monitorizare si control al traficului in Municipiul Brasov"			PLAN DE SITUATIE Semaforizare intersectie str. Valea Cetatii-str. Ghindei (Liceu)		Faza: SF
Proiectant: SC AM PROJECT DESIGN & CONSULTING SRL			Nr. desen:	246/71723-2208-SF-27.1	A3

SF 27.2: Valea Cetatii-Scoala 25

Molidului

Carpenuului

Valea Cetatii

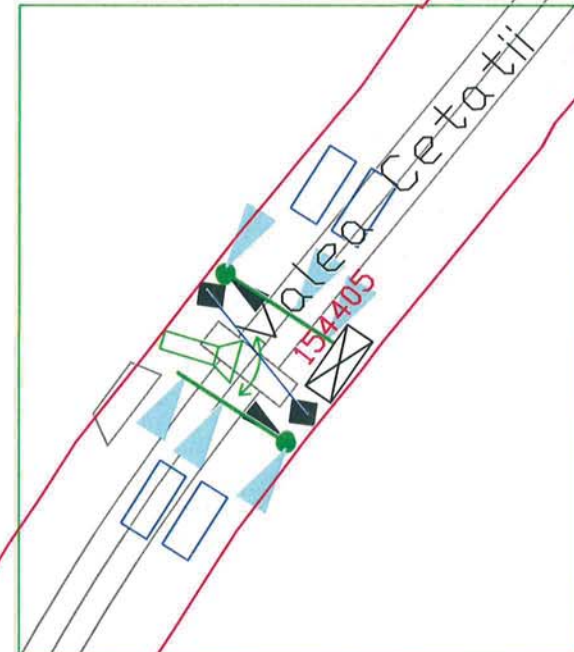

LEGENDA:

- semafor vehicule
- semafor pietoni
- VID/GIP
- buton semafor pietoni
- zona detectie video
- camera video fixa
- camera video mobila
- ADC
- stalp
- consola semafor
- camereta de tragere
- sapatura fibra optica
- detector vehicul oprit
- Dispozitiv radio LoRa
- zona studiata
- limita imobile
- Panou afisare



Proiectat	M. Grigore	Verificat	V. Stan	Aprobat	V. Stan
Desenat	M. Grigore	Data	octombrie 2018	Scara	
Denumire proiect: "Sistem centralizat de monitorizare si control al traficului in Municipiul Brasov"			PLAN DE SITUATIE Semaforizare intersectie str.Valea Cetatii-Scoala 25		Faza: SF
Proiectant: SC AM PROJECT DESIGN & CONSULTING SRL			Nr. desen: 246/71723-2208-SF-27.2		A3

SF 28.1: Str. Lunga -
Strada de Mijloc

JOS

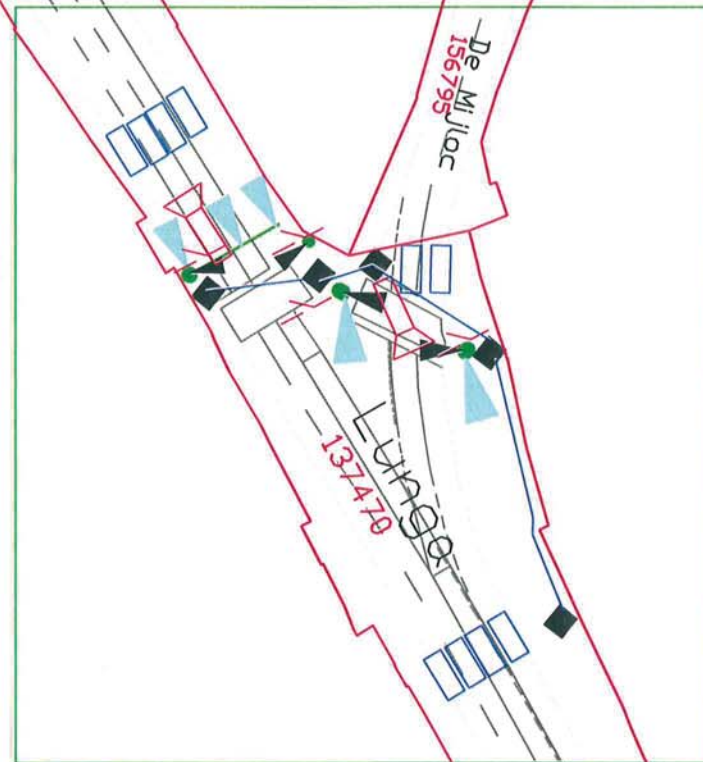

LEGENDA:

	semafor vehicule
	semafor pietoni
	VID/GIP
	buton semafor pietoni
	zona detectie video
	camera video fixa
	camera video mobila
	ADC
	stalp
	consola semafor
	camereta de tragere
	sapatura fibra optica
	detector vehicul oprit
	Dispozitiv radio LoRa
	zona studziata
	limita imobile
	Panou afisare



Figura
Faza: SF

Proiectat	M. Grigore	Verificat	V. Stan	Aprobat	V. Stan
Desenat	M. Grigore	Data	octombrie 2018	Scara	
Denumire proiect: "Sistem centralizat de monitorizare si control al traficului in Municipiul Brasov"			PLAN DE SITUATIE Semaforizare intersectie Str. Lunga - Strada de Mijloc		Faza: SF
Proiectant: SC AM PROJECT DESIGN & CONSULTING SRL			Nr. desen: 246/71723-2208-SF-28.1		A3

SF 28.2: Lunga-Biserica Romana (fosta Operetei)

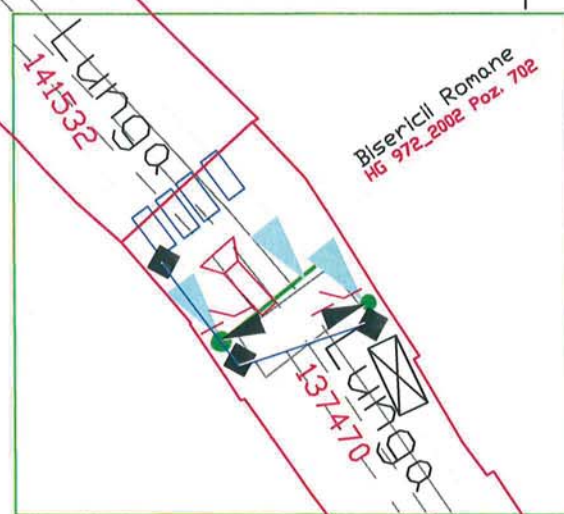

LEGENDA:

- semafor vehicule
- semafor pietoni
- VID/GIP
- buton semafor pietoni
- zona detectie video
- camera video fixa
- camera video mobila
- ADC
- stalp
- consola semafor
- camereta de tragere
- sapatura fibra optica
- detector vehicul oprit
- Dispozitiv radio LoRa
- zona studiata
- limita imobile
- Panou afisare



Proiectat	M. Grigore	Verificat	V. Stan	Aprobat	V. Stan
Desenat	M. Grigore	Data	octombrie 2018	Scara	
Denumire proiect: "Sistem centralizat de monitorizare si control al traficului in Municipiul Brasov"			PLAN DE SITUATIE Semaforizare intersectie Str. Lunga-str. Bisericii Romane (fosta Operetei)		Faza: SF
Proiectant: SC AM PROJECT DESIGN & CONSULTING SRL			Nr. desen:	246/71723-2208-SF-28.2	A3

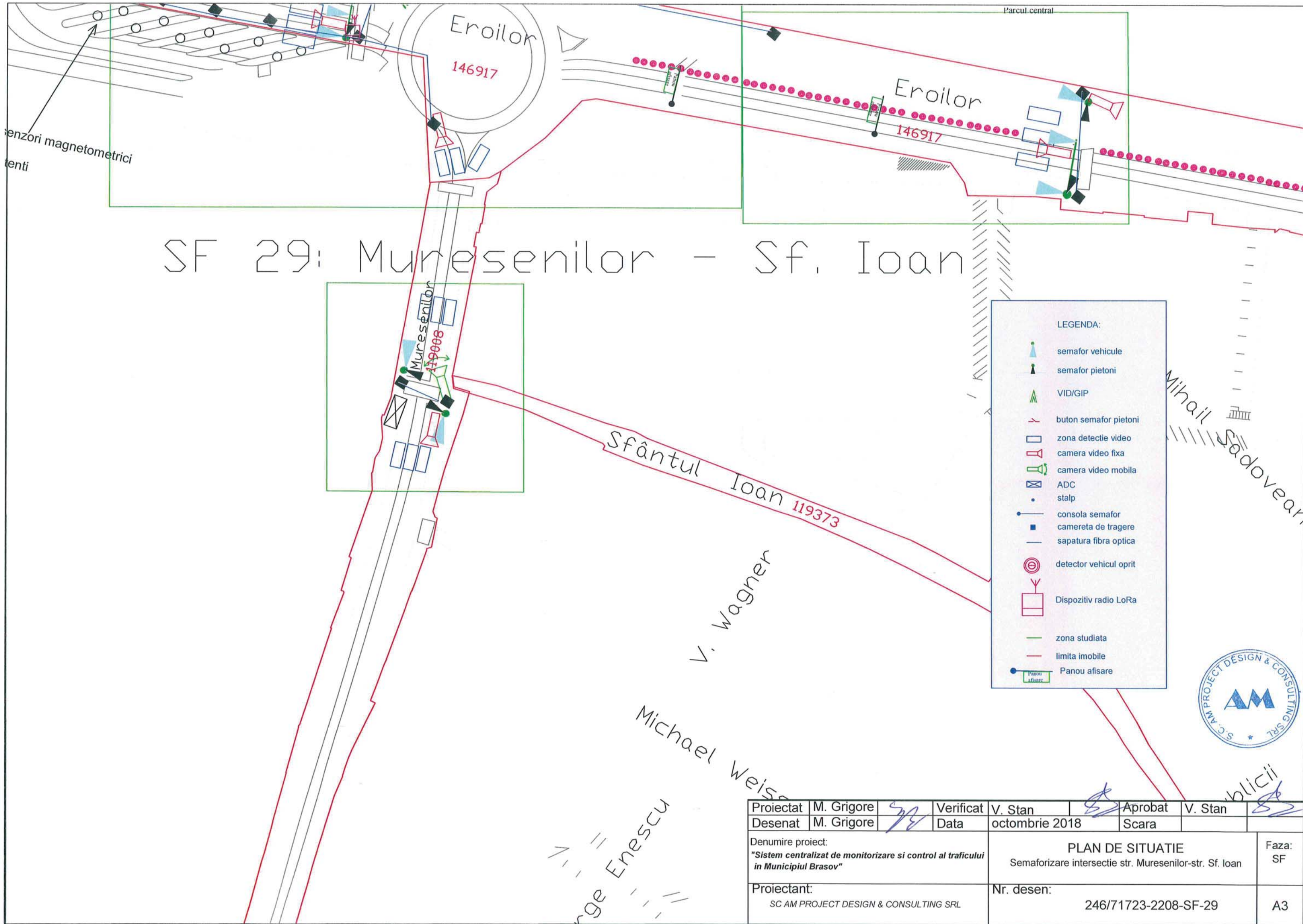

LEGENDA:

- semafor vehicule
- semafor pietoni
- VID/GIP
- buton semafor pietoni
- zona detectie video
- camera video fixa
- camera video mobila
- ADC
- stalp
- consola semafor
- camereta de tragere
- sapatura fibra optica
- detector vehicul oprit
- Dispozitiv radio LoRa
- zona studziata
- limita imobile
- Panou afisare

Proiectat	M. Grigore	Verificat	V. Stan	Aprobat	V. Stan
Desenat	M. Grigore	Data	octombrie 2018	Scara	
Denumire proiect: "Sistem centralizat de monitorizare si control al traficului in Municipiul Brasov"			PLAN DE SITUATIE Semaforizare intersectie str. Muresenilor-str. Sf. Ioan		Faza: SF
Proiectant: SC AM PROJECT DESIGN & CONSULTING SRL			Nr. desen: 246/71723-2208-SF-29		A3

Lunga

N. Iorga - 119356

N. Iorga - 119356

SF 30: Eroilor-Parc

Parcul central

Eroilor
146917

Eroilor
146917

resenilor - Sf. Ioan

Mihail Sadove

Sfântul Ioan 119373

agner

LEGENDA:

- semafor vehicule
- semafor pietoni
- VID/GIP
- buton semafor pietoni
- zona detectie video
- camera video fixa
- camera video mobila
- ADC
- stalp
- consola semafor
- camereta de tragere
- sapatura fibra optica
- detector vehicul oprit
- Dispozitiv radio LoRa
- zona studiata
- limita imobile
- Panou afisare



Proiectat	M. Grigore	Verificat	V. Stan	Aprobat	V. Stan
Desenat	M. Grigore	Data	octombrie 2018	Scara	
Denumire proiect: "Sistem centralizat de monitorizare si control al traficului in Municipiul Brasov"			PLAN DE SITUATIE Semaforizare intersectie Bd. Eroilor-Parc		Faza: SF
Proiectant: SC AM PROJECT DESIGN & CONSULTING SRL			Nr. desen: 246/71723-2208-SF-30		A3

SF 32: Garii-Victoriei

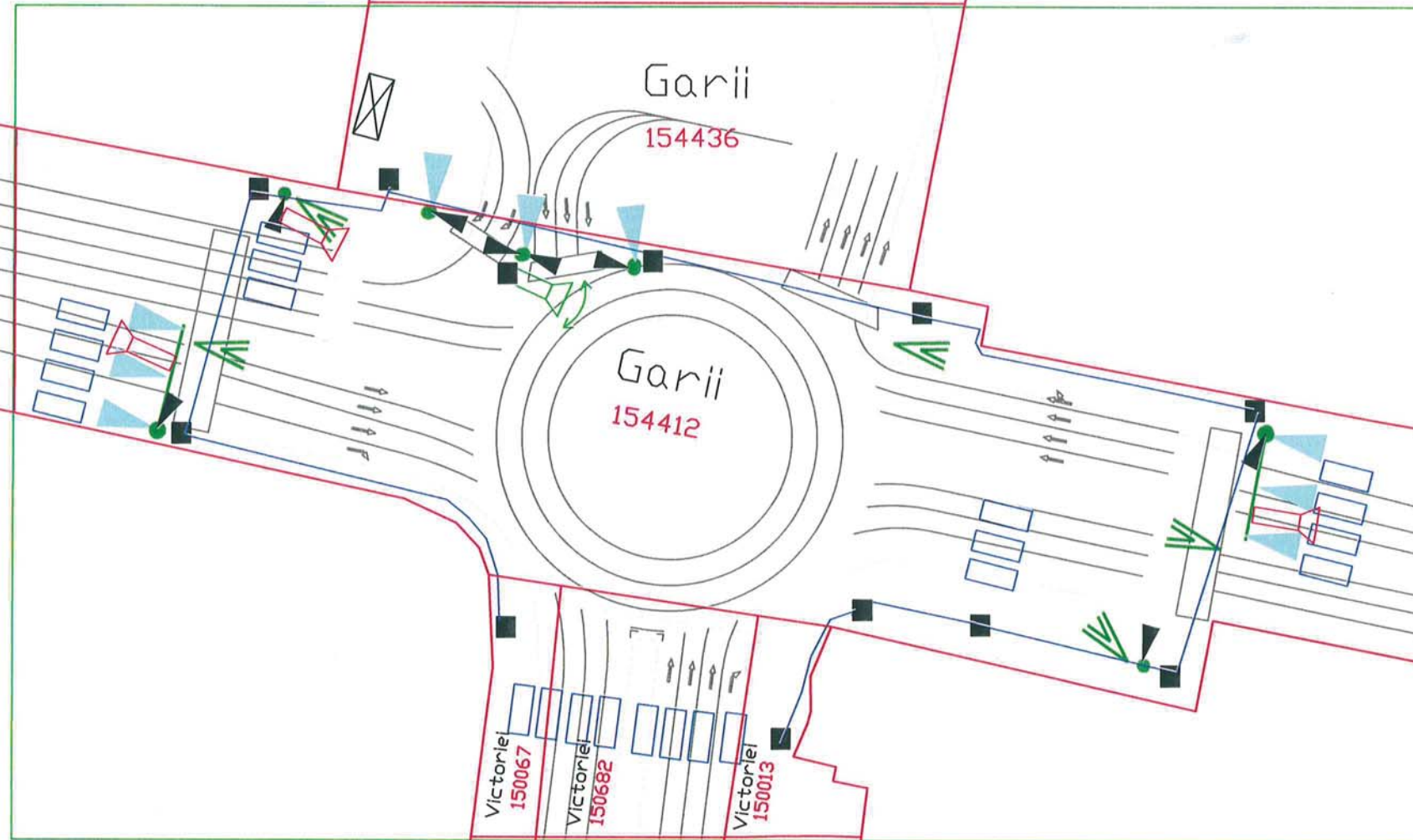

- LEGENDA:
- semafor vehicule
 - semafor pietoni
 - VID/GIP
 - buton semafor pietoni
 - zona detectie video
 - camera video fixa
 - camera video mobila
 - ADC
 - stalp
 - consola semafor
 - camereta de tragere
 - sapatura fibra optica
 - detector vehicul oprit
 - Dispozitiv radio LoRa
 - zona studiata
 - limita imobile
 - Panou afisare



Proiectat	M. Grigore		Verificat	V. Stan		Aprobat	V. Stan	
Desenat	M. Grigore		Data	octombrie 2018		Scara		
Denumire proiect:				PLAN DE SITUATIE				Faza:
"Sistem centralizat de monitorizare si control al traficului in Municipiul Brasov"				Semaforizare intersectie Bd. Garii-Bd. Victoriei				SF
Proiectant:				Nr. desen:				
SC AM PROJECT DESIGN & CONSULTING SRL				246/71723-2208-SF-32				A3

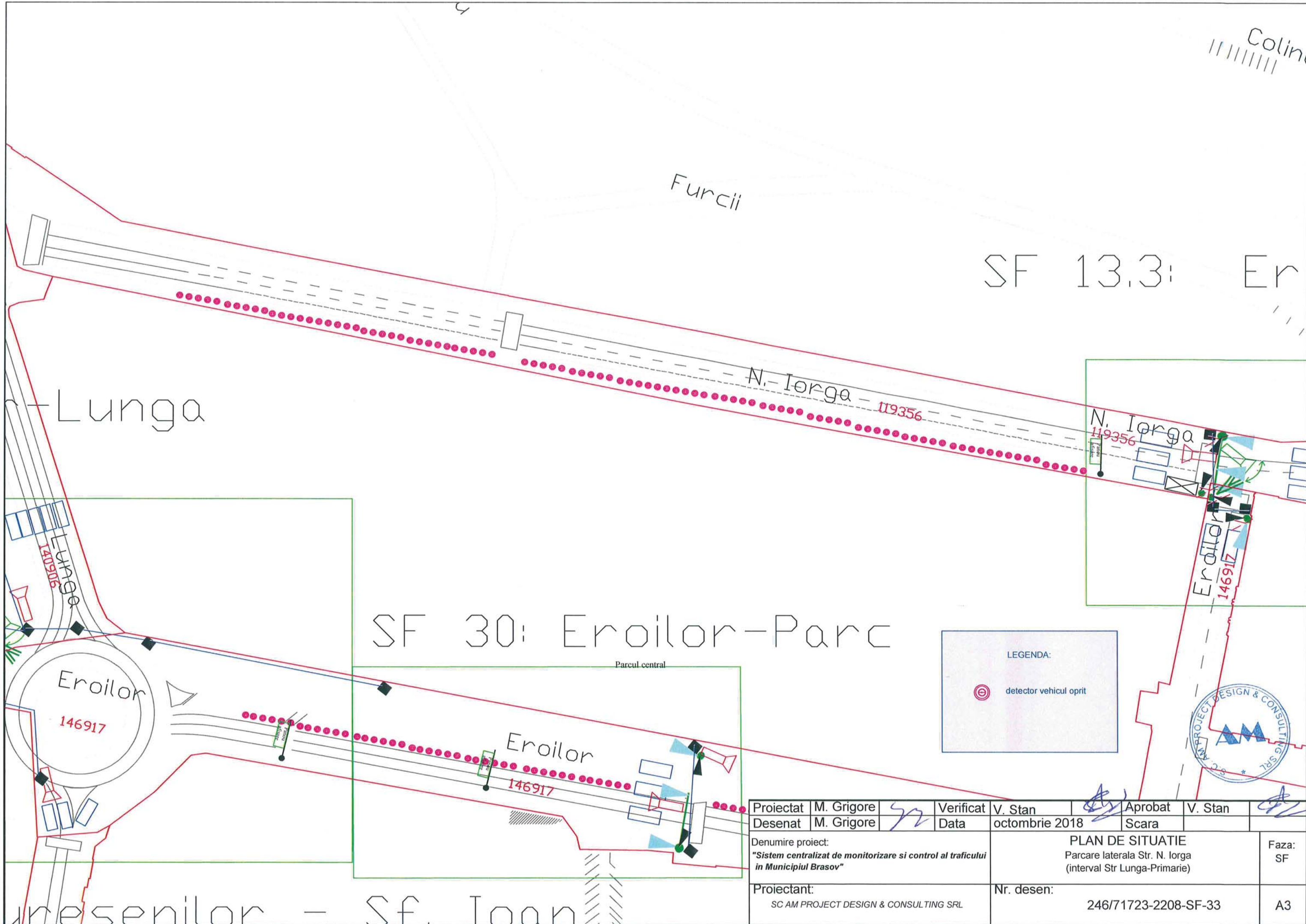

SF 13.3: Er

SF 30: Eroilor-Parc

LEGENDA:
 detector vehicul oprit

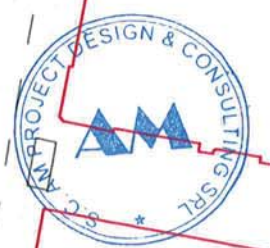

Proiectat	M. Grigore	Verificat	V. Stan	Aprobat	V. Stan
Desenat	M. Grigore	Data	octombrie 2018	Scara	
Denumire proiect: "Sistem centralizat de monitorizare si control al traficului in Municipiul Brasov"			PLAN DE SITUATIE Parcare laterala Str. N. Iorga (interval Str Lunga-Primarie)		Faza: SF
Proiectant: SC AM PROJECT DESIGN & CONSULTING SRL			Nr. desen: 246/71723-2208-SF-33		A3

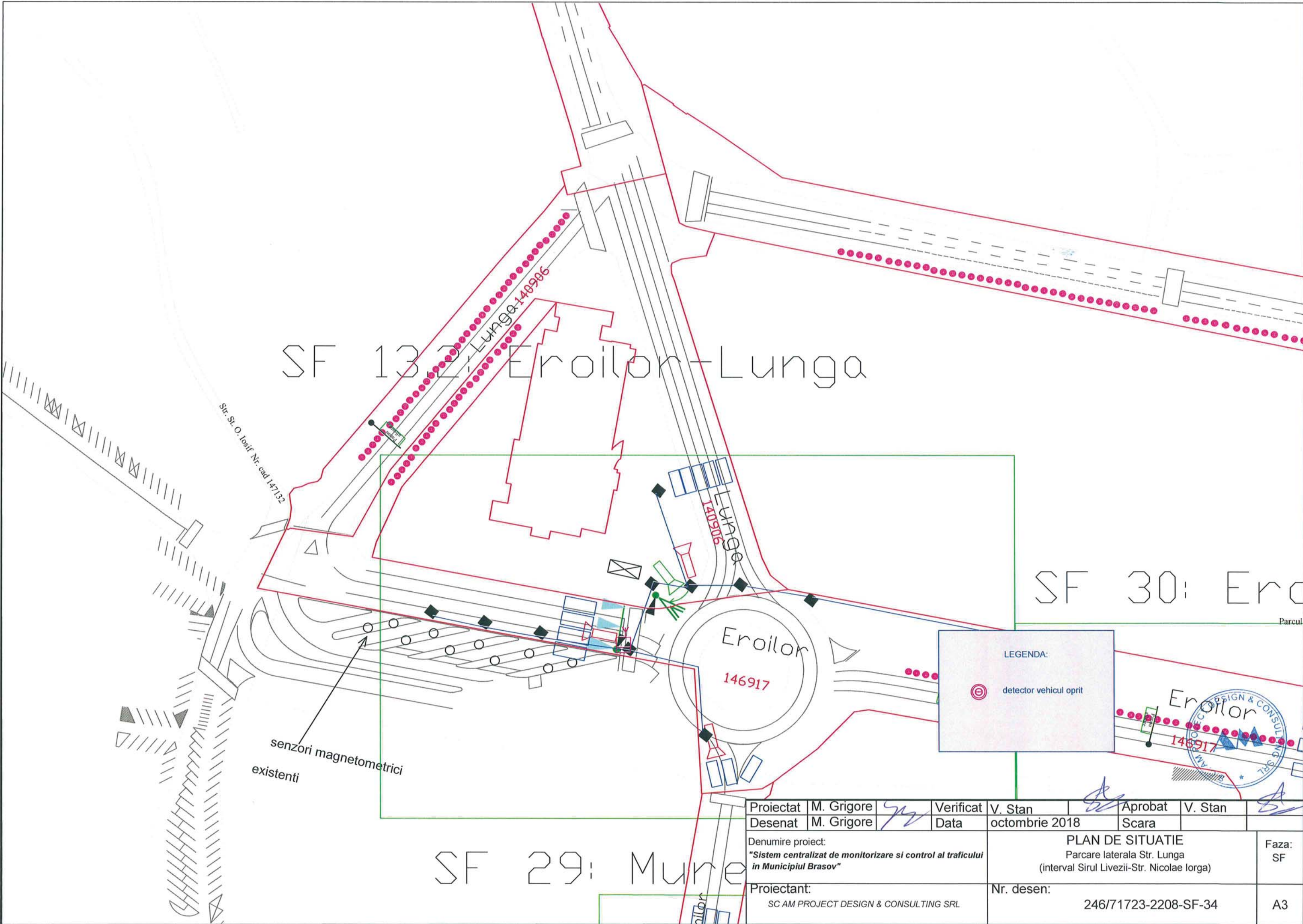

SF 132: Eroilor-Lunga

SF 30: Ero

SF 29: Mure

LEGENDA:

- detector vehicul oprit

senzori magnetometrici
existenti

Proiectat	M. Grigore	Verificat	V. Stan	Aprobat	V. Stan	
Desenat	M. Grigore	Data	octombrie 2018	Scara		
Denumire proiect:			PLAN DE SITUATIE		Faza:	
"Sistem centralizat de monitorizare si control al traficului in Municipiul Brasov"			Parcare laterala Str. Lunga (interval Sirul Livezii-Str. Nicolae Iorga)		SF	
Proiectant:			Nr. desen:			
SC AM PROJECT DESIGN & CONSULTING SRL			246/71723-2208-SF-34		A3	

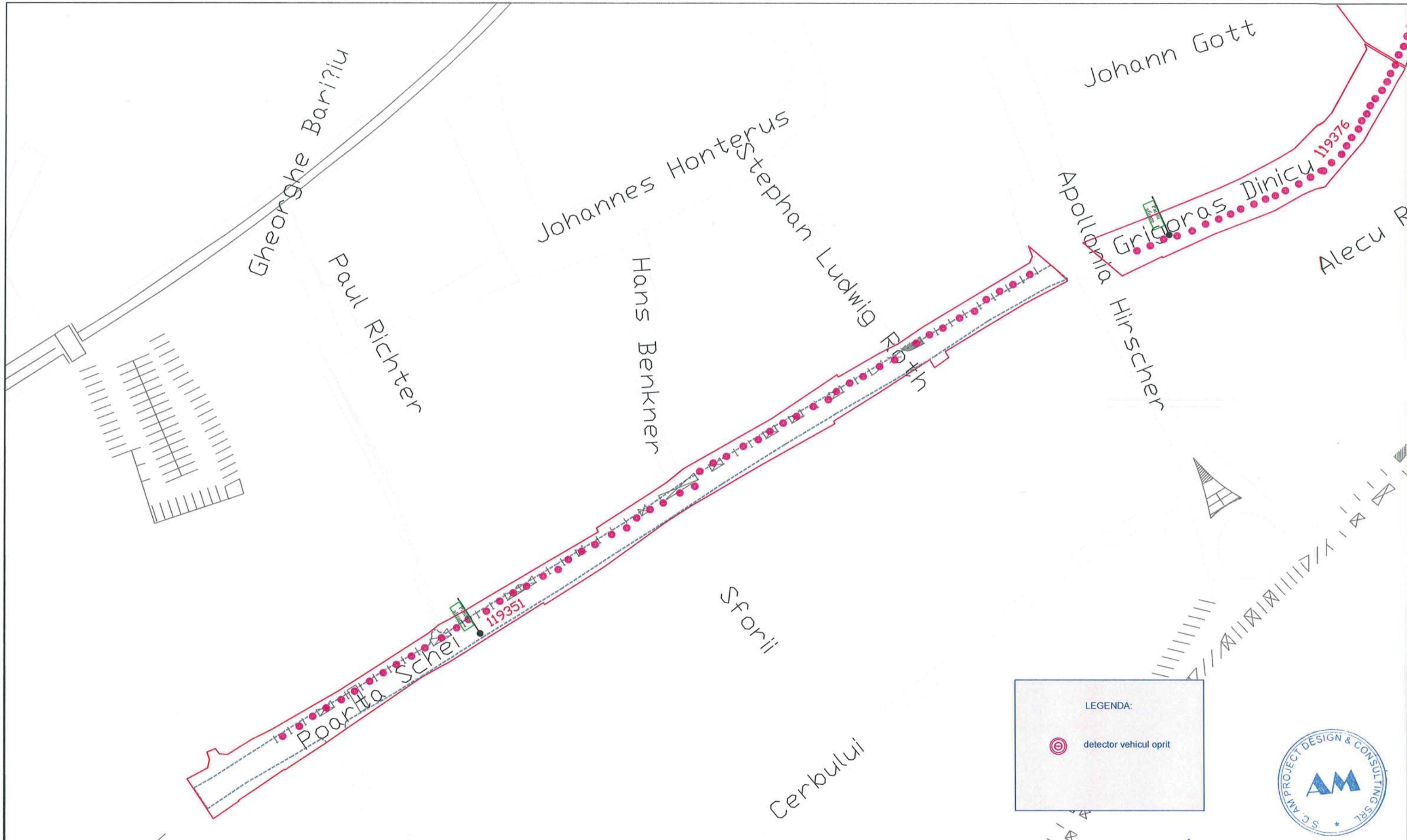

Proiectat	M. Grigore	Verificat	V. Stan	Aprobat	V. Stan
Desenat	M. Grigore	Data	octombrie 2018	Scara	
Denumire proiect: "Sistem centralizat de monitorizare si control al traficului in Municipiul Brasov"			PLAN DE SITUATIE Parcare laterala Str. Poarta Schei (interval str. Apollonia H.-str. Ludwig B.)		Faza: SF
Proiectant: SC AM PROJECT DESIGN & CONSULTING SRL			Nr. desen: 246/71723-2208-SF-35		A3

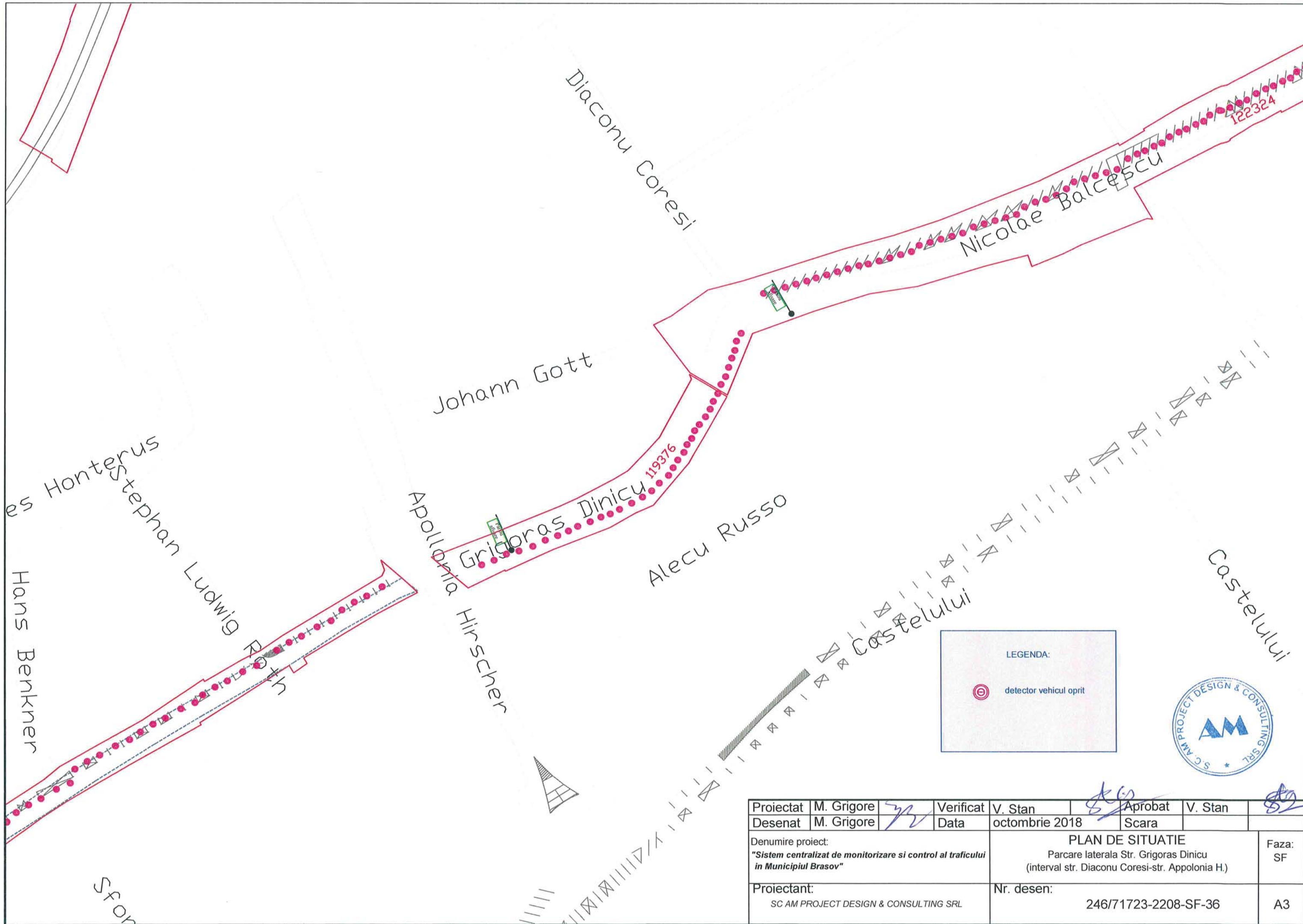

LEGENDA:

 detector vehicul oprit



Proiectat	M. Grigore	Verificat	V. Stan	Aprobat	V. Stan
Desenat	M. Grigore	Data	octombrie 2018	Scara	
Denumire proiect:			PLAN DE SITUATIE		Faza:
"Sistem centralizat de monitorizare si control al traficului in Municipiul Brasov"			Parcare laterala Str. Grigoras Dinicu (interval str. Diaconu Coresi-str. Appollonia H.)		SF
Proiectant:			Nr. desen:		
SC AM PROJECT DESIGN & CONSULTING SRL			246/71723-2208-SF-36		A3

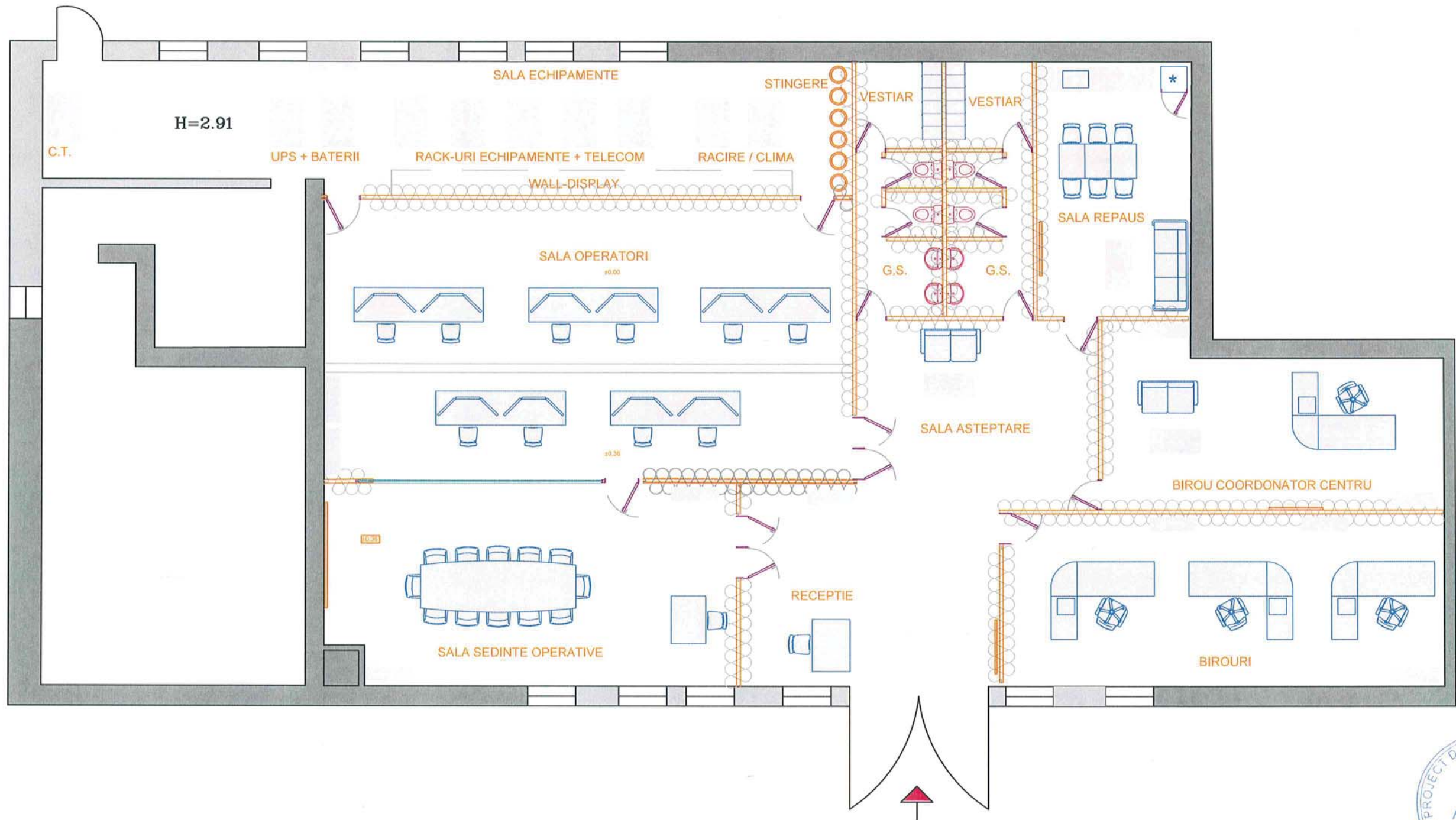

Proiectat	M. Grigore	<i>[Signature]</i>	Verificat	V. Stan	<i>[Signature]</i>	Aprobat	V. Stan	<i>[Signature]</i>
Desenat	M. Grigore	<i>[Signature]</i>	Data	octombrie 2018		Scara		
Denumire proiect: "Sistem centralizat de monitorizare si control al traficului in Municipiul Brasov"			Detaliu de executie: Plan amenajare Centru de Comanda si Control				Faza: SF	
Proiectant: SC AM PROJECT DESIGN & CONSULTING SRL			Nr. desen:		246/71723-2208-DDE-01		A3	

Sectiune fundatie

Scara 1:20

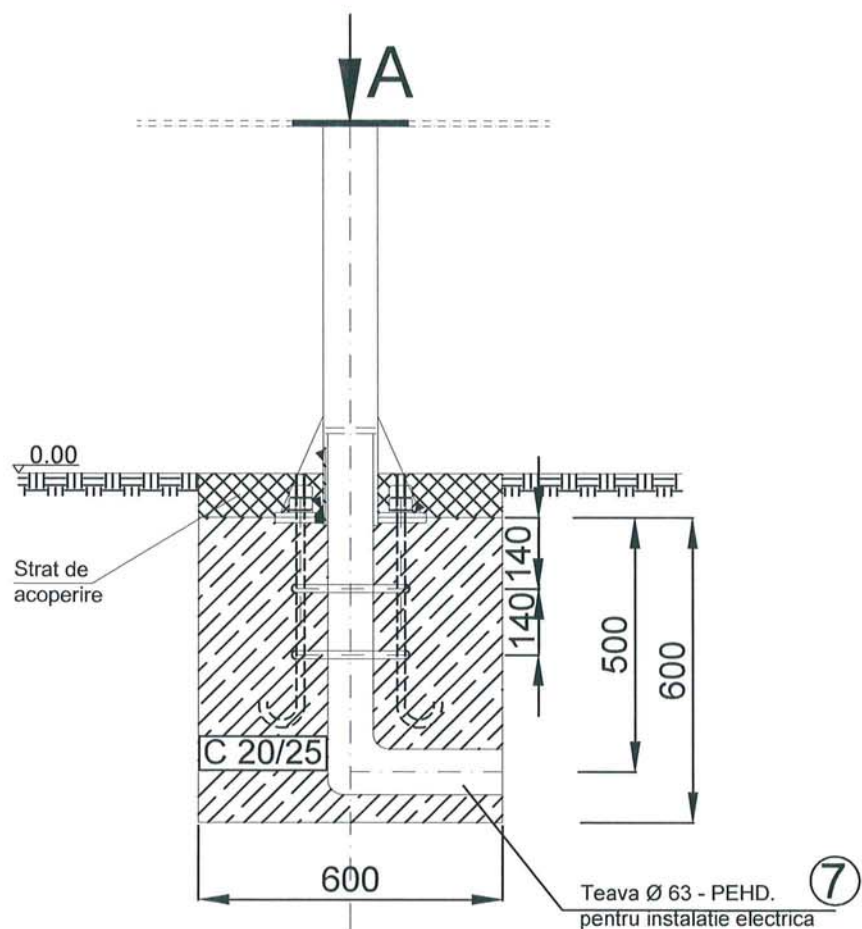

Vedere A

Scara 1:20

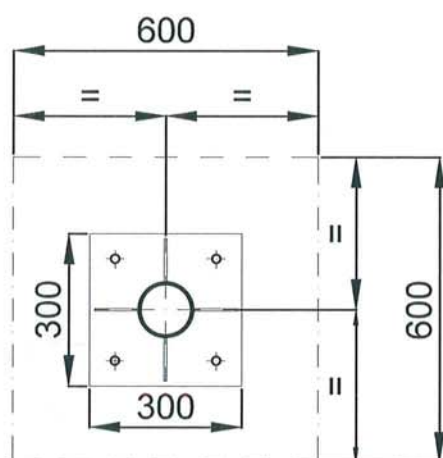

Placa

Scara 1:10

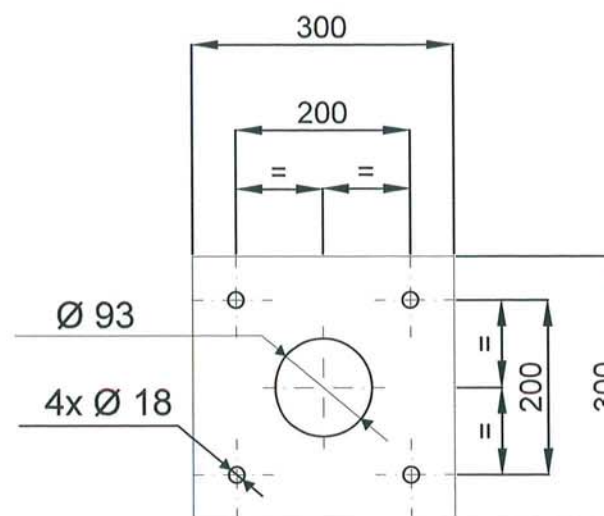

Detaliu surub pentru fundatie

Scara 1:10

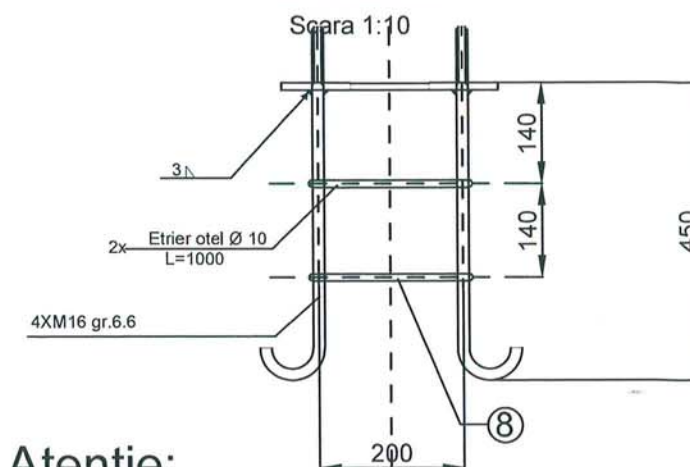

Atentie:

Etrierii se fixeaza pe suruburile de fundatie cu sarma la cotele indicate.

CERINTE PENTRU ASIGURAREA DURABILITATII LUCRARILOR
DIN BETON CONFORM CP012/1-2007

BETON / CONCRETE	C20/25
- CLASA DE EXPUNERE	XC2
- RAPORT MAX. APA-CIMENT	0.60
- DOZAJ MINIM DE CIMENT (kg/mc)	260
- TIP CIMENT	CEMII/A, B-S;A,B-V; A, B-LL; CEMIII/A

Nota:

Protectia suprafetelor:curat

Muchiile placii se tesesc :1*45°

Dupa sudura cordoanele se vor curata si

verifica continuitatea

Filetele vor fi protejate cu bucati de tub PVC



Proiectat	M. Grigore	Verificat	V. Stan	Aprobat	V. Stan
Desenat	M. Grigore	Data	octombrie 2018	Scara	
Denumire proiect: "Sistem centralizat de monitorizare si control al traficului in Municipiul Brasov"			Detaliu de executie: Fundatie stalp simplu pentru semafor		Faza: SF
Proiectant: SC AM PROJECT DESIGN & CONSULTING SRL			Nr. desen: 246/71723-2208-DDE-02		A3

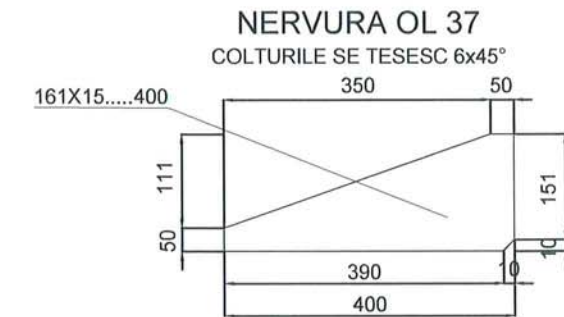
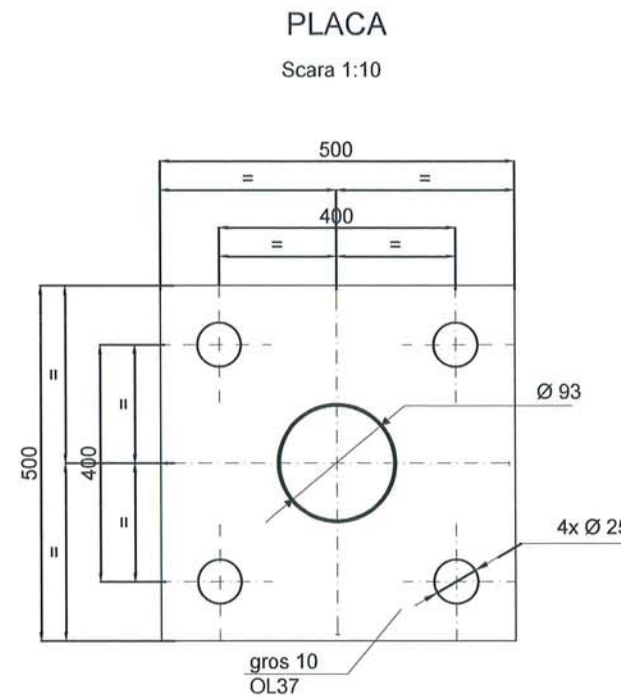
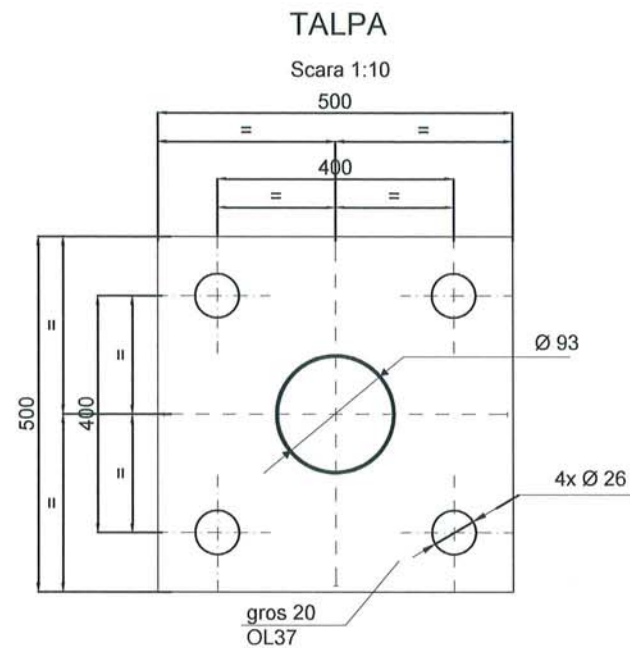
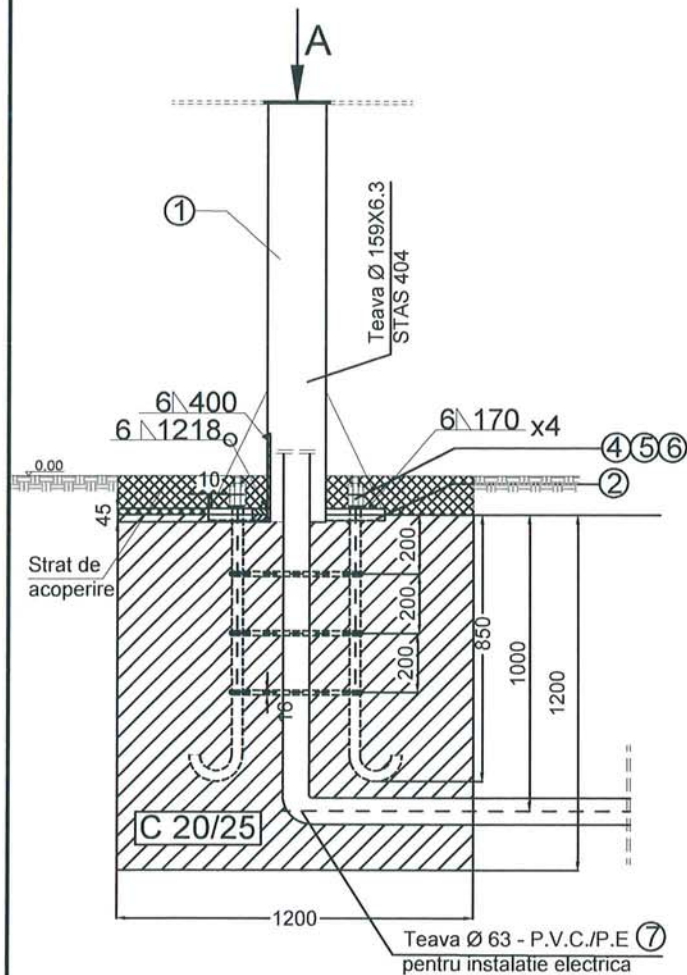

VEDERE A
Scara 1:2

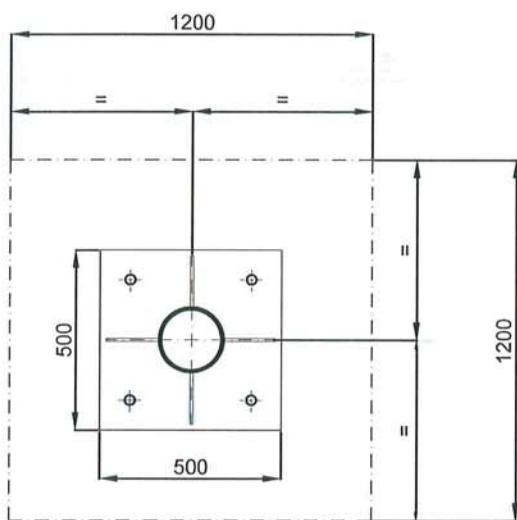

Detaliu surub pentru fundatie
Scara 1:10

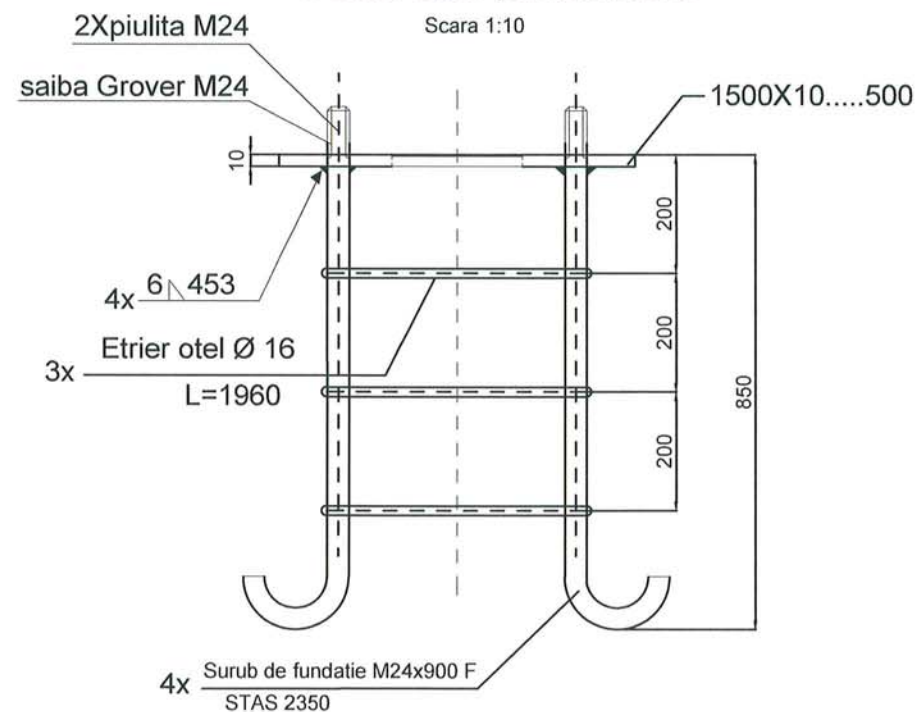

Poz.	Denumire	Nr. desen sau STAS	Buc.	Material	Observatii	Masa
8	Etrier		2	OLC 65		
6	Teava racord		1	PVC Ø63		
5	Saiba Grover N24	SR7666/2-94	4	OIT 65	zincat	pt.fixare
4	Saiba A24	STAS 5200	4	OL 37	zincat	pt.fixare
3	Piulita inalta M24	STAS 4372	8	8	zincat	pt.fixare
2	Surub spec. M24x900F	STAS 2350	4	8.8		
1	Placa		1	OL 37 (42)		

CERINTE PENTRU ASIGURAREA DURABILITATII LUCRARILOR
DIN BETON CONFORM CP012/1-2007

BETON / CONCRETE	C20/25
- CLASA DE EXPUNERE	XC2
- RAPORT MAX. APA-CIMENT	0.60
- DOZAJ MINIM DE CIMENT (kg/mc)	260
- TIP CIMENT	CEMII/A; B-S;A,B-V; A, B-LI; CEMIII/A

Nota:

Protectia suprafetelor:curat
Muchiile placii se tesesc :1*45°
Dupa sudura cordoanele se vor curata si
verifica continuitatea
Filetele vor fi protejate cu bucati de tub PVC

Atentie:

Etrierii se fixeaza pe suruburile de fundatie cu sarma
la cotele indicate.

Proiectat	M. Grigore	Verificat	V. Stan	Aprobat	V. Stan
Desenat	M. Grigore	Data	octombrie 2018	Scara	
Denumire proiect: "Sistem centralizat de monitorizare si control al traficului in Municipiul Brasov"			Detaliu de executie: Fundatie stalp cu consola pentru semafor		Faza: SF
Proiectant: SC AM PROJECT DESIGN & CONSULTING SRL			Nr. desen: 246/71723-2208-DDE-03		A3

**CAMERA TRAGERE MARE DIN BETON C20/25
AMPLASATA IN ZONA VERDE SAU TROTUAR**

VEDERE B-B
Rama si capac canalizare necarosabil 600x600 -capac fonta.
Clasa B125 conform E.N.124

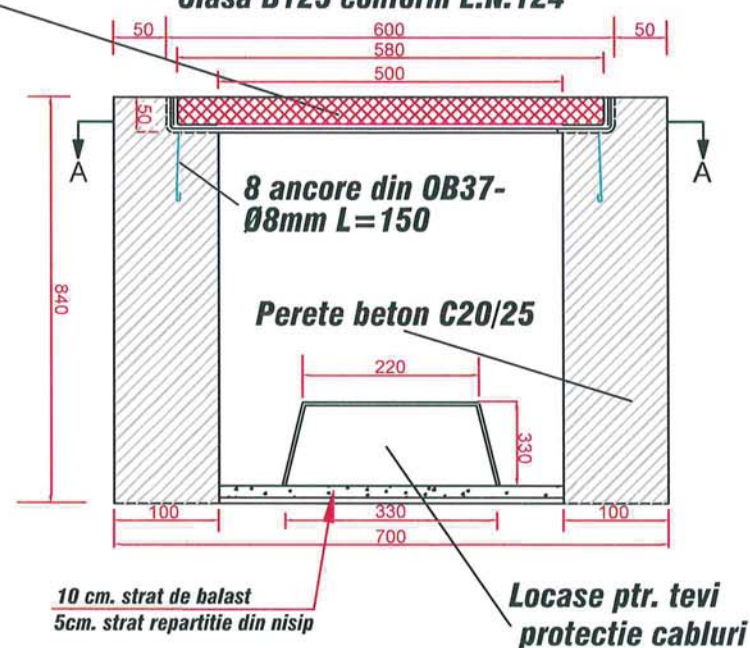

NOTA:

- Cotele sunt date in milimetri
- Ptr. executie pereti, se folosesc cofrje lemn sau metal.
- Dimensiunea locaselor ptr. tevine de protectie cabluri, in functie de numarul tevilor din documentatie executie.
- In locul locasurilor trapezoidale, se pot monta capete de teava, cu diam 110 mm., din PVC. coaxiale cu tevine din canalizatie.
- Incarcare maxima 40t.

VEDERE A-A
Rama si capac canalizare necarosabil 600x600 -capac fonta.
Clasa B125 conform E.N.124

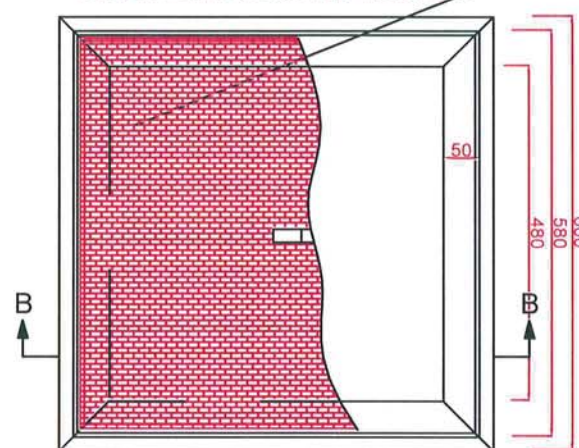

CERINTE PENTRU ASIGURAREA DURABILITATII LUCRARILOR
DIN BETON CONFORM CP012/1-2007

BETON / CONCRETE	C20/25
- CLASA DE EXPUNERE	XC2
- RAPORT MAX. APA-CIMENT	0.60
- DOZAJ MINIM DE CIMENT (kg/mc)	260
- TIP CIMENT	CEMII/A, B-S;A,B-V; A, B-LL; CEMIII/A



Proiectat	M. Grigore	Verificat	V. Stan	Aprobat	V. Stan
Desenat	M. Grigore	Data	octombrie 2018	Scara	
Denumire proiect: "Sistem centralizat de monitorizare si control al traficului in Municipiul Brasov"			Detaliu de executie: Camera de tragere		Faza: SF
Proiectant: SC AM PROJECT DESIGN & CONSULTING SRL			Nr. desen: 246/71723-2208-DDE-04		A3

Sectiune transversala prin santul pentru cabluri in carosabil

Sectiune transversala prin santul pentru cabluri (2 tuburi)

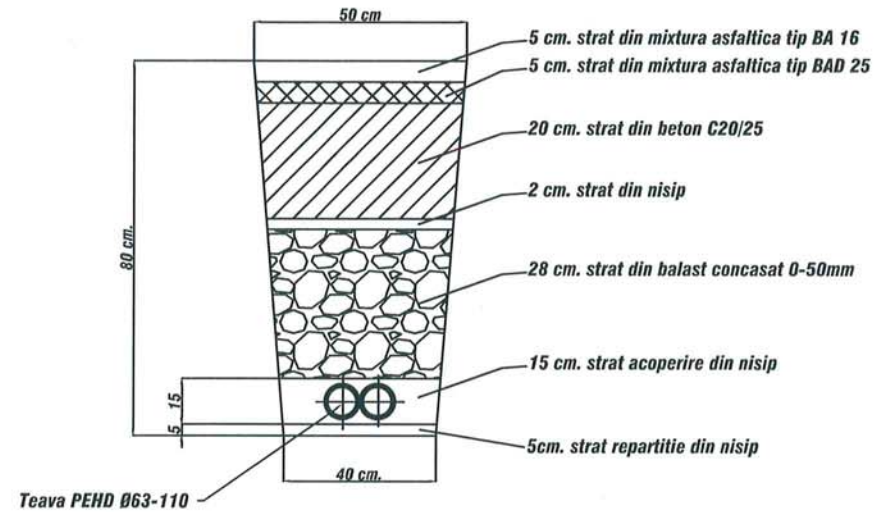

Nota:

Se va respecta structura sistemului rutier existent

Sectiune transversala prin santul pentru cabluri in zona trotuarului

Sectiune transversala prin santul pentru cabluri (1 tub)

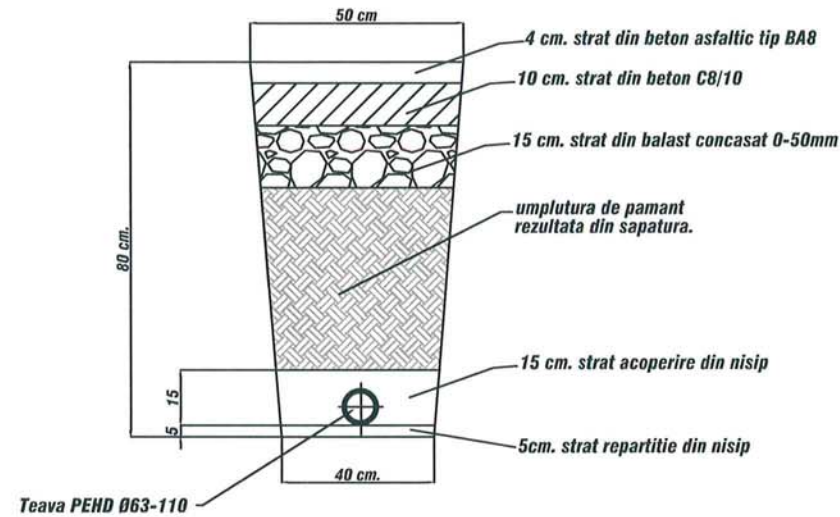

Sectiune transversala prin santul pentru cabluri (2 tuburi)

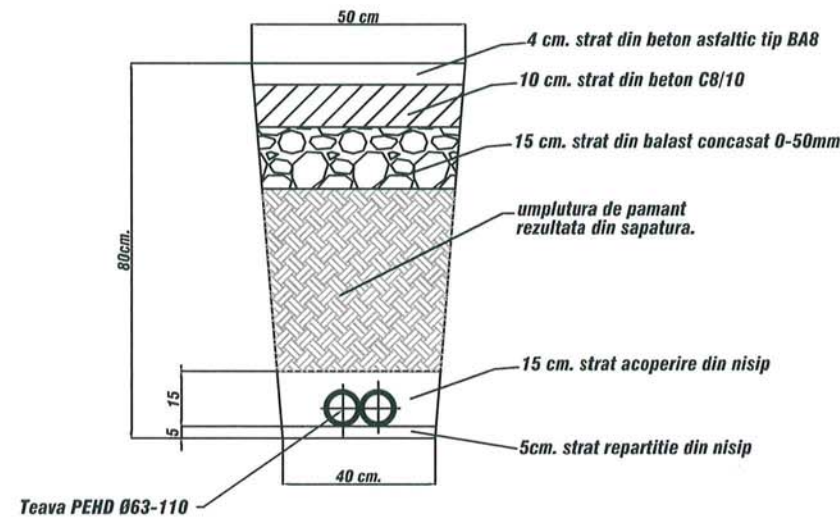

Nota:

Se va respecta structura sistemului pietonal existent

Sectiune transversala prin santul pentru cabluri in spatiul verde

Sectiune transversala prin santul pentru cabluri (1 tub)

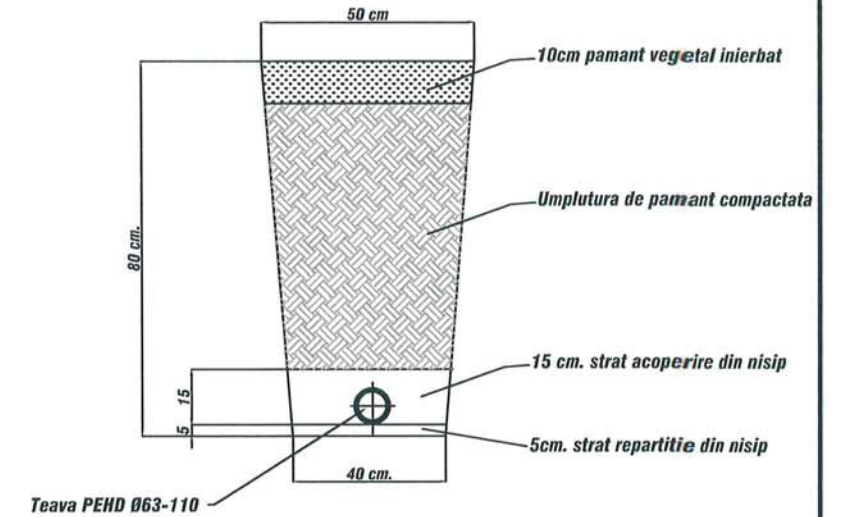

Sectiune transversala prin santul pentru cabluri (2 tuburi)

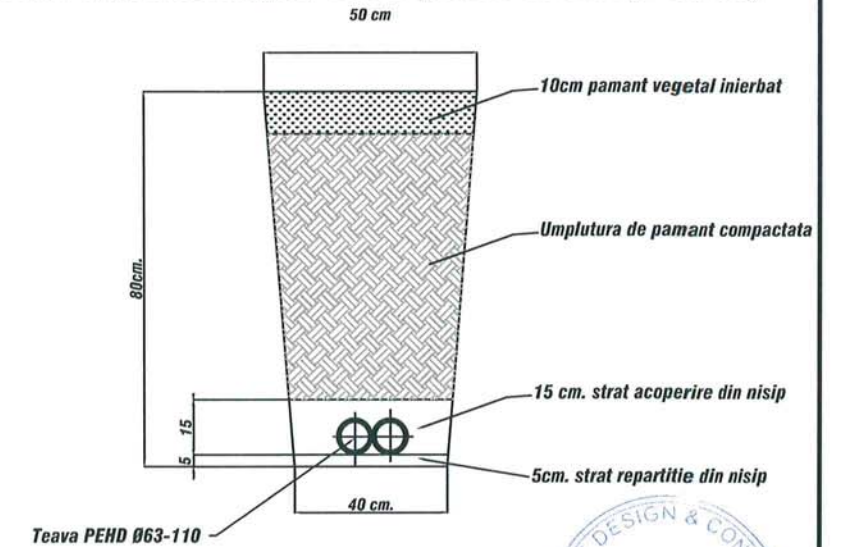

CERINTE PENTRU ASIGURAREA DURABILITATII LUCRARILOR DIN BETON CONFORM CP 012/1-2007

BETON	C20/25
- CLASA DE EXPUNERE	XC2
- RAPORT MAX. APA-CIMENT	0.60
- DOZAJ MINIM DE CIMENT (kg/mc)	260
- TIP CIMENT	CEMII/A, B-S;A,B-V; A, B-LI; CEMIII/A

Proiectat	M. Grigore	Verificat	V. Stan	Aprobat	V. Stan
Desenat	M. Grigore	Data	octombrie 2018	Scara	
Denumire proiect: "Sistem centralizat de monitorizare si control al traficului in Municipiul Brasov"			Detaliu de executie: Canalizatie electrica subterana		Faza: SF
Proiectant: SC AM PROJECT DESIGN & CONSULTING SRL			Nr. desen: 246/71723-2208-DDE-05		A3

FUNDATIE DULAP A.D.C. - DIN BETON C20/25

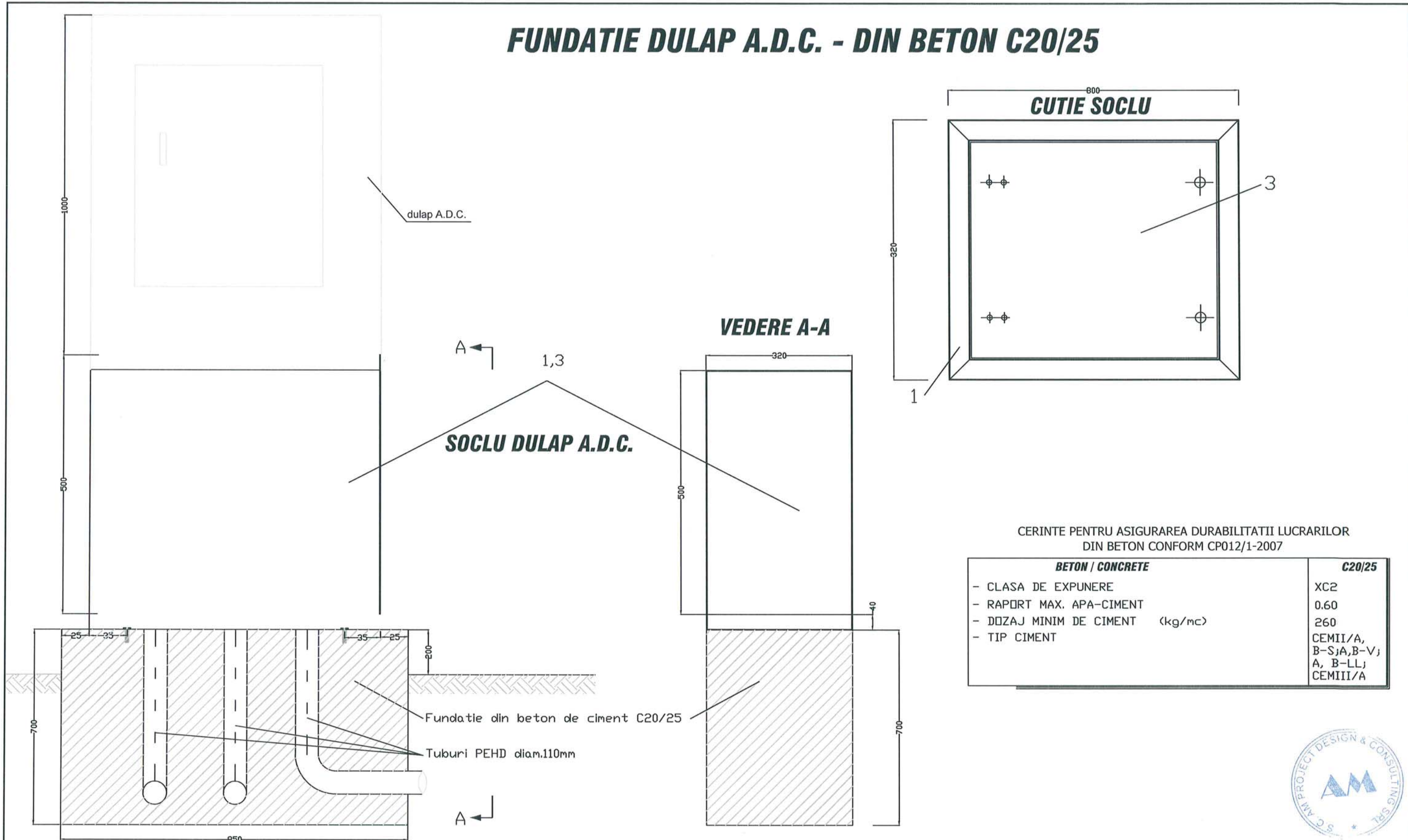

CERINTE PENTRU ASIGURAREA DURABILITATII LUCRARILOR
DIN BETON CONFORM CP012/1-2007

BETON / CONCRETE	C20/25
- CLASA DE EXPUNERE	XC2
- RAPORT MAX. APA-CIMENT	0.60
- DOZAJ MINIM DE CIMENT (kg/mc)	260
- TIP CIMENT	CEMII/A, B-S;A,B-V; A, B-LL; CEMIII/A



NOTA:

Numarul de tevi din fundatia ADC-ului vor fi de 3 bucati Ø110mm.
Asamblarea poz. 1 cu poz. 2 se face cu 4 suruburi M8x50, 4 piulite M8, 8 saibe A8

Proiectat	M. Grigore	Verificat	V. Stan	Aprobat	V. Stan
Desenat	M. Grigore	Data	octombrie 2018	Scara	
Denumire proiect: "Sistem centralizat de monitorizare si control al traficului in Municipiul Brasov"			Detaliu de executie: Fundatie dulap ADC		Faza: SF
Proiectant: SC AM PROJECT DESIGN & CONSULTING SRL			Nr. desen: 246/71723-2208-DDE-06		A3